

RST# LOW ACTIVE (POWER RESET)
CS# LOW ACTIVE (CHIP SELECT)
IOR# LOW ACTIVE (IO DATA READ)
IOW# LOW ACTIVE (IO DATA WRITE)
INT HIGH ACTIVE (INTERRUPT ACTIVE)

JP1 ON : USE 8 Bit MODE
 OFF : USE 16 Bit MODE
JP2 ON : USE EEPROM
 OFF : NOT USE EEPROM

FOR NORMAL SYSTEM
 JP3 2-3 SHORT , JP4 2-3 SHORT
FOR X86 ISA SYSTEM 16 Bit Mode TEST
 JP3 1-2 SHORT , JP4 2-3 SHORT
FOR MDC/MDIO 16 Bit Mode Test
 JP3 OPEN , JP4 OPEN

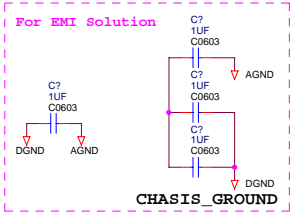
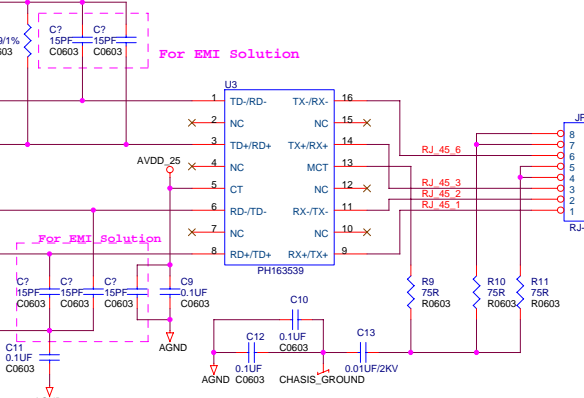
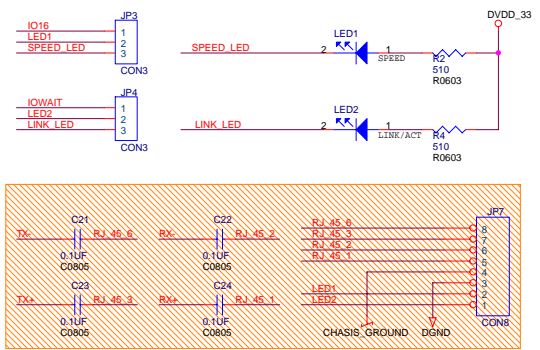
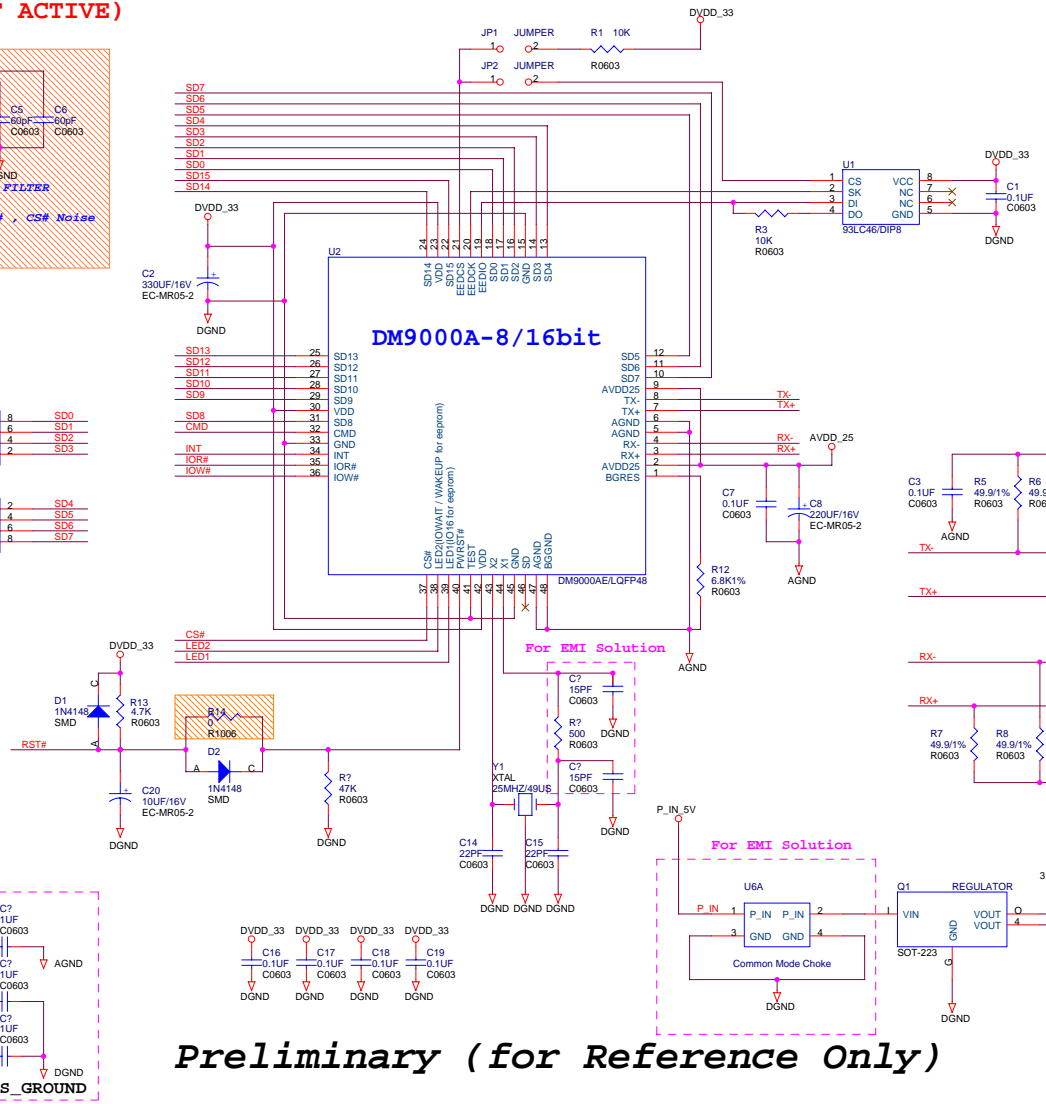
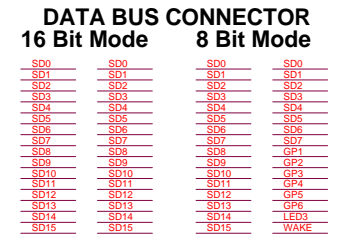
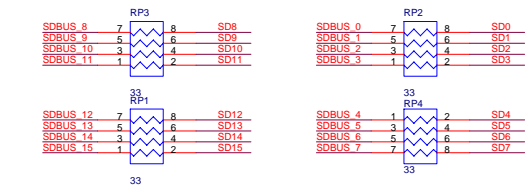
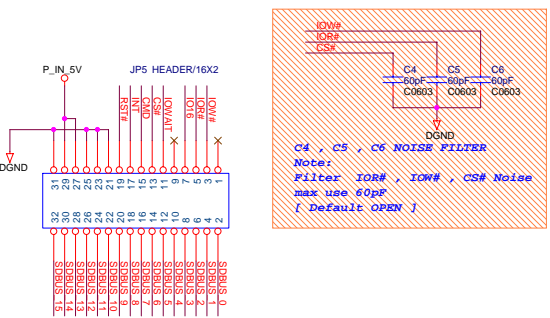

Preliminary (for Reference Only)

Title		DAVICOM Semiconductor Inc.	
Size	Document Number	DM9000A-8/16bit TX AUTO-MIDX	
Custom	Rev	2.0	
Date:	Thursday, April 20, 2006	Sheet	1 of 1