



Power.org™ Standard for Embedded Power Architecture™ Platform Requirements
(ePAPR)

Version 1.1 – 08 April 2011

Copyright © 2008,2011 Power.org. All rights reserved.

The Power Architecture and Power.org word marks and the Power and Power.org logos and related marks are trademarks and service marks licensed by Power.org.

Implementation of certain elements of this document may require licenses under third party intellectual property rights, including without limitation, patent rights. Power.org and its Members are not, and shall not be held, responsible in any manner for identifying or failing to identify any or all such third party intellectual property rights.

THIS POWER.ORG SPECIFICATION PROVIDED “AS IS” AND WITHOUT ANY WARRANTY OF ANY KIND, INCLUDING, WITHOUT LIMITATION, ANY EXPRESS OR IMPLIED WARRANTY OF NON-INFRINGEMENT, MERCHANTABILITY OR FITNESS FOR A PARTICULAR PURPOSE. IN NO EVENT SHALL POWER.ORG OR ANY MEMBER OF POWER.ORG BE LIABLE FOR ANY DIRECT, INDIRECT, SPECIAL, EXEMPLARY, PUNITIVE, OR CONSEQUENTIAL DAMAGES, INCLUDING, WITHOUT LIMITATION, LOST PROFITS, EVEN IF ADVISED OF THE POSSIBILITY OF SUCH DAMAGES.

Questions pertaining to this document, or the terms or conditions of its provision, should be addressed to:

IEEE-ISTO
445 Hoes Lane
Piscataway, NJ 08854
Attn: Power.org Board Secretary

LICENSE INFORMATION

© Copyright 2008,2011 Power.org, Inc

© Copyright Freescale Semiconductor, Inc., 2008,2011

© Copyright International Business Machines Corporation, 2008,2011

All Rights Reserved.

Table of Contents

| | |
|--|-----------|
| REVISION HISTORY | 7 |
| 1 INTRODUCTION | 8 |
| 1.1 PURPOSE AND SCOPE..... | 8 |
| 1.2 RELATIONSHIP TO IEEE™ 1275..... | 10 |
| 1.3 32-BIT AND 64-BIT SUPPORT | 10 |
| 1.4 REFERENCES..... | 11 |
| 1.5 DEFINITION OF TERMS..... | 13 |
| 2 THE DEVICE TREE | 14 |
| 2.1 OVERVIEW | 14 |
| 2.2 DEVICE TREE STRUCTURE AND CONVENTIONS..... | 15 |
| 2.2.1 <i>Node Names</i> | 15 |
| 2.2.2 <i>Generic Names Recommendation</i> | 17 |
| 2.2.3 <i>Path Names</i> | 18 |
| 2.2.4 <i>Properties</i> | 18 |
| 2.3 STANDARD PROPERTIES..... | 21 |
| 2.3.1 <i>compatible</i> | 21 |
| 2.3.2 <i>model</i> | 21 |
| 2.3.3 <i>phandle</i> | 22 |
| 2.3.4 <i>status</i> | 23 |
| 2.3.5 <i>#address-cells and #size-cells</i> | 24 |
| 2.3.6 <i>reg</i> | 25 |
| 2.3.7 <i>virtual-reg</i> | 25 |
| 2.3.8 <i>ranges</i> | 26 |
| 2.3.9 <i>dma-ranges</i> | 28 |
| 2.3.10 <i>name</i> | 29 |
| 2.3.11 <i>device_type</i> | 29 |
| 2.4 INTERRUPTS AND INTERRUPT MAPPING | 30 |
| 2.4.1 <i>Properties for Interrupt Generating Devices</i> | 32 |
| 2.4.2 <i>Properties for Interrupt Controllers</i> | 33 |
| 2.4.3 <i>Interrupt Nexus Properties</i> | 33 |
| 2.4.4 <i>Interrupt Mapping Example</i> | 35 |
| 3 DEVICE NODE REQUIREMENTS | 37 |
| 3.1 BASE DEVICE NODE TYPES | 37 |
| 3.2 ROOT NODE | 37 |
| 3.3 ALIASES NODE..... | 38 |
| 3.4 MEMORY NODE | 39 |
| 3.5 CHOSEN | 40 |
| 3.6 CPUS NODE PROPERTIES | 41 |
| 3.7 CPU NODE PROPERTIES | 41 |
| 3.7.1 <i>General Properties of CPU nodes</i> | 42 |
| 3.7.2 <i>TLB Properties</i> | 44 |
| 3.7.3 <i>Internal (L1) Cache Properties</i> | 45 |

| | | |
|----------|--|-----------|
| 3.7.4 | <i>Example</i> | 46 |
| 3.8 | MULTI-LEVEL AND SHARED CACHES | 46 |
| 4 | CLIENT PROGRAM IMAGE FORMAT | 48 |
| 4.1 | VARIABLE ADDRESS IMAGE FORMAT | 48 |
| 4.1.1 | <i>ELF Basics</i> | 48 |
| 4.1.2 | <i>Boot Program Requirements</i> | 48 |
| 4.1.3 | <i>Client Program Requirements</i> | 49 |
| 4.2 | FIXED ADDRESS IMAGE FORMAT | 50 |
| 5 | CLIENT PROGRAM BOOT REQUIREMENTS | 51 |
| 5.1 | BOOT AND SECONDARY CPUs | 51 |
| 5.2 | DEVICE TREE | 51 |
| 5.3 | INITIAL MAPPED AREAS | 51 |
| 5.4 | CPU ENTRY POINT REQUIREMENTS | 52 |
| 5.4.1 | <i>Boot CPU Initial Register State</i> | 52 |
| 5.4.2 | <i>I/O Devices State</i> | 53 |
| 5.4.3 | <i>Initial I/O Mappings (IIO)</i> | 53 |
| 5.4.4 | <i>Boot CPU Entry Requirements: Real Mode</i> | 54 |
| 5.4.5 | <i>Boot CPU Entry Requirements for IMAs: Book III-E</i> | 54 |
| 5.5 | SYMMETRIC MULTIPROCESSING (SMP) BOOT REQUIREMENTS | 55 |
| 5.5.1 | <i>Overview</i> | 55 |
| 5.5.2 | <i>Spin Table</i> | 56 |
| 5.5.3 | <i>Implementation-Specific Release from Reset</i> | 59 |
| 5.5.4 | <i>Timebase Synchronization</i> | 59 |
| 5.6 | ASYMMETRIC CONFIGURATION CONSIDERATIONS | 59 |
| 6 | DEVICE BINDINGS | 60 |
| 6.1 | BINDING GUIDELINES | 60 |
| 6.1.1 | <i>General Principles</i> | 60 |
| 6.1.2 | <i>Miscellaneous Properties</i> | 61 |
| 6.2 | SERIAL DEVICES | 62 |
| 6.2.1 | <i>Serial Class Binding</i> | 62 |
| 6.2.2 | <i>National Semiconductor 16450/16550 Compatible UART Requirements</i> | 63 |
| 6.3 | NETWORK DEVICES | 63 |
| 6.3.1 | <i>Network Class Binding</i> | 63 |
| 6.3.2 | <i>Ethernet specific considerations</i> | 64 |
| 6.4 | OPEN PIC INTERRUPT CONTROLLERS | 66 |
| 6.5 | SIMPLE-BUS | 66 |
| 7 | VIRTUALIZATION | 67 |
| 7.1 | OVERVIEW | 67 |
| 7.2 | HYPERCALL APPLICATION BINARY INTERFACE (ABI) | 67 |
| 7.3 | ePAPR HYPERCALL TOKEN DEFINITION | 68 |
| 7.4 | HYPERCALL RETURN CODES | 69 |
| 7.5 | HYPERSVISOR NODE | 70 |
| 7.6 | ePAPR VIRTUAL INTERRUPT CONTROLLER SERVICES | 71 |
| 7.6.1 | <i>Virtual Interrupt Controller Device Tree Representation</i> | 71 |

| | | |
|----------|---|------------|
| 7.6.2 | <i>ePAPR Interrupt Controller Hypercalls</i> | 73 |
| 7.7 | BYTE-CHANNEL SERVICES | 80 |
| 7.7.1 | <i>Overview</i> | 80 |
| 7.7.2 | <i>Interrupts and Guest Device Tree Representation</i> | 81 |
| 7.7.3 | <i>Byte-channel Hypercalls</i> | 82 |
| 7.8 | INTER-PARTITION DOORBELLS | 84 |
| 7.8.1 | <i>Overview</i> | 84 |
| 7.8.2 | <i>Doorbell Send Endpoints</i> | 84 |
| 7.8.3 | <i>Doorbell Receive Endpoints</i> | 84 |
| 7.8.4 | <i>Doorbell Hypercall</i> | 85 |
| 7.9 | MSGSEND | 85 |
| 7.9.1 | <i>EV_MSGSEND</i> | 85 |
| 7.10 | IDLE | 86 |
| | <i>EV_IDLE</i> | 86 |
| 8 | FLAT DEVICE TREE PHYSICAL STRUCTURE | 87 |
| 8.1 | VERSIONING | 87 |
| 8.2 | HEADER | 88 |
| 8.3 | MEMORY RESERVATION BLOCK | 89 |
| 8.3.1 | <i>Purpose</i> | 89 |
| 8.3.2 | <i>Format</i> | 90 |
| 8.4 | STRUCTURE BLOCK | 91 |
| 8.4.1 | <i>Lexical structure</i> | 91 |
| 8.4.2 | <i>Tree structure</i> | 92 |
| 8.5 | STRINGS BLOCK | 93 |
| 8.6 | ALIGNMENT | 94 |
| | APPENDIX A DEVICE TREE SOURCE FORMAT (VERSION 1) | 95 |
| | APPENDIX B1 EBONY DEVICE TREE | 97 |
| | APPENDIX B2 – MPC8572DS DEVICE TREE | 104 |

Acknowledgements

The power.org Platform Architecture Technical Subcommittee would like thank the many individuals and companies that contributed to the development this specification through writing, technical discussions and reviews.

Individuals (in alphabetical order)

Hollis Blanchard
Dan Bouvier
Josh Boyer
Becky Bruce
Dale Farnsworth
Kumar Gala
David Gibson
Ben Herrenschmidt
Dan Hettena
Olof Johansson
Ashish Kalra
Grant Likely
Jon Loeliger
Hartmut Penner
Tim Radzykewycz
Heiko Schick
Timur Tabi
John Traill
John True
Matt Tyrlik
Dave Willoughby
Scott Wood
Jimi Xenidis
Stuart Yoder

Companies

Freescale Semiconductor
Green Hills Software
IBM
Montavista
Wind River

Other Acknowledgements

Significant aspects of the ePAPR device tree are based on work done by the Open Firmware Working Group which developed bindings for IEEE-1275. We would like to acknowledge their contributions.

We would also like to acknowledge the contribution of the PowerPC Linux community that initially developed and implemented the flattened device tree concept.

Revision History

| Revision | Date | Description |
|----------|-----------|--|
| 1.0 | 7/23/2008 | Initial Version |
| 1.1 | 3/7/2011 | Updates include: virtualization chapter, consolidated representation of cpu nodes, <i>stdin/stdout</i> properties on <i>/chosen</i> , <i>label</i> property, representation of hardware threads on cpu nodes, representation of Power ISA categories on cpu nodes, mmu type property, removal of some bindings, additional cpu entry requirements for threaded cpus, miscellaneous cleanup and clarifications. |

1 Introduction

1.1 Purpose and Scope

To initialize and boot a computer system, various software components interact—firmware might perform low-level initialization of the system hardware before passing control to software such as an operating system, bootloader, or hypervisor. Bootloaders and hypervisors can, in turn, load and transfer control to operating systems. Standard, consistent interfaces and conventions facilitate the interactions between these software components. In this document the term *boot program* is used to generically refer to a software component that initializes the system state and executes another software component referred to as a *client program*. Examples of a boot programs include: firmware, bootloaders, and hypervisors. Examples of a client program include: bootloaders, hypervisors, operating systems, and special purpose programs. A piece of software (e.g. a hypervisor) may be both a client program and a boot program.

This specification, the Embedded Power Architecture Platform Requirements (ePAPR), provides a complete boot program to client program interface definition, combined with minimum system requirements that facilitate the development of a wide variety of embedded systems based on CPUs that implement the Power architecture as defined in the Power ISA™ [1].

This specification is targeted towards the requirements of embedded systems. An embedded system typically consists of system hardware, an operating system, and application software that are custom designed to perform a fixed, specific set of tasks. This is unlike general purpose computers, which are designed to be customized by a user with a variety of software and I/O devices. Other characteristics of embedded systems can include:

- a fixed set of I/O devices, possibly highly customized for the application
- a system board optimized for size and cost
- limited user interface
- resource constraints like limited memory and limited nonvolatile storage
- real-time constraints
- use of a wide variety of operating systems, including Linux, real-time operating systems, and custom or proprietary operating systems

1

2 **Organization of this Document**

3

4

- Chapter 1 introduces the architecture being specified by the ePAPR.

5

- Chapter 2 introduces the device tree concept and describes its logical structure and standard properties.

6

7

- Chapter 3 specifies the definition of a base set of device nodes required by ePAPR-compliant device trees.

8

9

Chapter 4 specifies the ELF client program image format.

10

- Chapter 5 specifies the requirements for boot programs to start client programs on single and multiple CPU systems.

11

12

- Chapter 6 describes device bindings for certain classes of devices and specific device types.

13

- Chapter 7 describes ePAPR virtualization extensions-- hypercall ABI, hypercall APIs, and device tree conventions related to virtualization.

14

15

- Chapter 8 specifies the physical structure of device trees.

16

17

18

19 **Conventions Used in this Document**

20

The word *shall* is used to indicate mandatory requirements strictly to be followed in order to conform to the standard and from which no deviation is permitted (*shall* equals *is required to*).

21

22

The word *should* is used to indicate that among several possibilities one is recommended as particularly suitable, without mentioning or excluding others; or that a certain course of action is preferred but not necessarily required; or that (in the negative form) a certain course of action is deprecated but not prohibited (*should* equals *is recommended that*).

23

24

25

26

The word *may* is used to indicate a course of action permissible within the limits of the standard (*may* equals *is permitted*).

27

28

Examples of device tree constructs are frequently shown in *Device Tree Syntax* form. See *Appendix A Device Tree Source Format (version 1)* for an overview of this syntax.

29

30

1 **1.2 Relationship to IEEE™ 1275**

2
3 The ePAPR is loosely related to the IEEE 1275 Open Firmware standard—*IEEE Standard for Boot*
4 *(Initialization Configuration) Firmware: Core Requirements and Practices* [2].

5
6 The original IEEE 1275 specification and its derivatives such as CHRP [10] and PAPR [16] address
7 problems of general purpose computers, such as how a single version of an operating system can work
8 on several different computers within the same family and the problem of loading an operating system
9 from user-installed I/O devices.

10
11 Because of the nature of embedded systems, some of these problems faced by open, general purpose
12 computers do not apply. Notable features of the IEEE 1275 specification that are omitted from the
13 ePAPR include:

- 14 • Plug-in device drivers
- 15 • FCode
- 16 • The programmable Open Firmware user interface based on Forth
- 17 • FCode debugging
- 18 • Operating system debugging

19
20 What *is* retained from IEEE-1275 are concepts from the device tree architecture by which a boot
21 program can describe and communicate system hardware information to client program, thus
22 eliminating the need for the client program to have hard-coded descriptions of system hardware.

23 **1.3 32-bit and 64-bit Support**

24
25 The ePAPR supports CPUs with both 32-bit and 64-bit addressing capabilities. Where applicable,
26 sections of the ePAPR describe any requirements or considerations for 32-bit and 64-bit addressing.
27
28
29

1.4 References

1. *Power ISA™*, Version 2.06 Revision B, July 23, 2010. It is available from power.org (<http://power.org>).
2. *Boot (Initialization Configuration) Firmware: Core Requirements and Practices*, 1994. This is the core standard (also known as IEEE 1275) that defines the device tree concept adopted by the ePAPR. It is available from Global Engineering (<http://global.ihs.com/>).
3. *PowerPC Processor Binding to IEEE 1275-1994 Standard for Boot (Initialization, Configuration) Firmware*. Version 2.1 1996. Published by the Open Firmware Working Group. (http://playground.sun.com/1275/bindings/ppc/release/ppc-2_1.html). This document specifies the PowerPC processor specific binding to the base standard.
4. *booting-without-of.txt* (Ben Herrenschmidt, Becky Bruce, et al.). From the Linux kernel source tree (<http://www.kernel.org/>). Describes the device tree as used by the Linux kernel.
5. *Device Trees Everywhere*. By .David Gibson and Ben Herrenschmidt (<http://ozlabs.org/~dgibson/home/papers/dtc-paper.pdf>). An overview of the concept of the device tree and device tree compiler.
6. *PCI Bus Binding to: IEEE Std 1275-1994 Standard for Boot (Initialization Configuration) Firmware*, Revision 2.1. 1998. Published by the Open Firmware Working Group. (http://playground.sun.com/1275/bindings/pci/pci2_1.pdf)
7. *Open Firmware Recommended Practice: Interrupt Mapping*, Version 0.9. 1996. Published by the Open Firmware Working Group. (http://playground.sun.com/1275/practice/imap/imap0_9d.pdf)
8. *Open Firmware Recommended Practice: Device Support Extensions*, Version 1.0, 1997. Published by the Open Firmware Working Group. (http://playground.sun.com/1275/practice/devicex/dse1_0a.html) This document describes the binding for various device types such as network, RTC, keyboard, sound, etc.
9. *Open Firmware Recommended Practice: Universal Serial Bus Binding to IEEE 1275*, Version 1, 1998. Published by the Open Firmware Working Group. (http://playground.sun.com/1275/bindings/usb/usb-1_0.ps)
10. *PowerPC Microprocessor Common Hardware Reference Platform (CHRP) Binding*, Version 1.8, 1998. Published by the Open Firmware Working Group. (http://playground.sun.com/1275/bindings/chrp/chrp1_8a.ps). This document specifies the properties for Open PIC-compatible interrupt controllers.
11. *CHRP ISA Interrupt Controller Device Binding*, Unapproved Draft version 1.1, Aug 19, 1996, Published by the Open Firmware Working Group. (http://playground.sun.com/1275/bindings/devices/postscript/isa-pic-1_1d.ps)

-
- 1 12. *The Open Programmable Interrupt Controller (PIC) Register Interface Specification Revision 1.2*,
2 October 1995. Advanced Micro Devices and Cyrix Corporation.
 - 3
 - 4 13. *PCI Local Bus Specification*, Revision 2.2. Published by the PCI Special Interest Group.
 - 5
 - 6 14. *PCI Express Base Specification*, Revision 1.0a. Published by the PCI Special Interest Group.
 - 7
 - 8 15. *PCI-Express Binding to OF*. P1275 Openboot Working Group Proposal dated 18 August 2004.
 - 9
 - 10 16. *Power.org Standard for Power Architecture Platform Requirements*, Published by power.org.
 - 11
 - 12 17. *System V Application Binary Interface*, Edition 4.1, 1997, Published by The Santa Cruz Operation,
13 Inc.
 - 14
 - 15 18. *The Open Programmable Interrupt Controller (PIC) Register Interface Specification Revision 1.2*,
16 AMD and Cyrix. October 1995.
 - 17
 - 18 19. *RFC 2119, Key words for use in RFCs to Indicate Requirement Levels*
19 <http://www.ietf.org/rfc/rfc2119.txt>
 - 20
 - 21 20. *64-bit PowerPC ELF Application Binary Interface Supplement 1.9*. By Ian Lance Taylor. 2004.
 - 22
 - 23
 - 24
 - 25

1

2 **1.5 Definition of Terms**

3

4

5

6

7

8

9

10

11

12

13

14

15

16

17

18

19

20

21

22

23

24

25

26

27

28

29

30

31

32

33

34

35

36

37

38

39

40

41

- **AMP**. Asymmetric Multiprocessing. Computer architecture where two or more CPUs are executing different tasks. Typically, an AMP system executes different operating system images on separate CPUs.
- **boot CPU**. The first CPU which a boot program directs to a client program's entry point.
- **Book III-E**. Embedded Environment. Section of the Power ISA defining supervisor instructions and related facilities used in embedded Power processor implementations.
- **boot program**. Used to generically refer to a software component that initializes the system state and executes another software component referred to as a client program. Examples of a boot programs include: firmware, bootloaders, and hypervisors. Examples of a client program include: bootloaders, hypervisors, operating systems, and special purpose programs.
- **client program**. Program that typically contains application or operating system software.
- **cell**. A unit of information consisting of 32 bits.
- **DMA**. Direct memory access
- **DTB**. Device tree blob. Compact binary representation of the device tree.
- **DTC**. Device tree compiler. An open source tool used to create DTB files from DTS files.
- **DTS**. Device tree syntax. A textual representation of a device tree consumed by the DTC. See Appendix A Device Tree Source Format (version 1).
- **effective address**. Memory address as computed by processor storage access or branch instruction.
- **physical address**. Address used by the processor to access external device, typically a memory controller. The Power ISA uses the *real address* when referring to a physical address.
- **Power ISA**. Power Instruction Set Architecture.
- **interrupt specifier**. A property value that describes an interrupt. Typically information that specifies an interrupt number and sensitivity and triggering mechanism is included.
- **secondary CPU**. CPUs other than the boot CPU that belong to the client program are considered *secondary CPUs*.
- **SMP**. Symmetric multiprocessing. A computer architecture where two or more identical CPUs can execute the same task. Typically an SMP system executes a single operating system image.
- **SOC**. System on a chip. A single computer chip integrating one or more CPU core as well as number of other peripherals.
- **unit address**. The part of a node name specifying the node's address in the address space of the parent node.
- **quiescent CPU**. A quiescent CPU is in a state where it cannot interfere with the normal operation of other CPUs, nor can its state be affected by the normal operation of other running CPUs, except by an explicit method for enabling or re-enabling the quiescent CPU.

2 The Device Tree

2.1 Overview

The ePAPR specifies a construct called a *device tree* to describe system hardware. A boot program loads a device tree into a client program's memory and passes a pointer to the device tree to the client.

This chapter describes the logical structure of the device tree and specifies a base set of properties for use in describing device nodes. Chapter 3 specifies certain device nodes required by an ePAPR-compliant device tree. Chapter 6 describes the ePAPR defined device bindings—the requirements for representing certain device types classes of devices. Chapter 8 describes the in-memory encoding of the device tree.

A device tree is a tree data structure with nodes that describe the devices in a system. Each node has property/value pairs that describe the characteristics of the device being represented. Each node has exactly one parent except for the root node, which has no parent.

An ePAPR-compliant device tree describes device information in a system that cannot necessarily be dynamically detected by a client program. For example, the architecture of PCI enables a client to probe and detect attached devices, and thus device tree nodes describing PCI devices might not be required. However, a device node is required to describe a PCI host bridge device in the system if it cannot be detected by probing.

Example

Figure 2-1 shows an example representation of a simple device tree that is nearly complete enough to boot a simple operating system, with the platform type, CPU, and memory described. Device nodes are shown with properties and values shown beside the node.

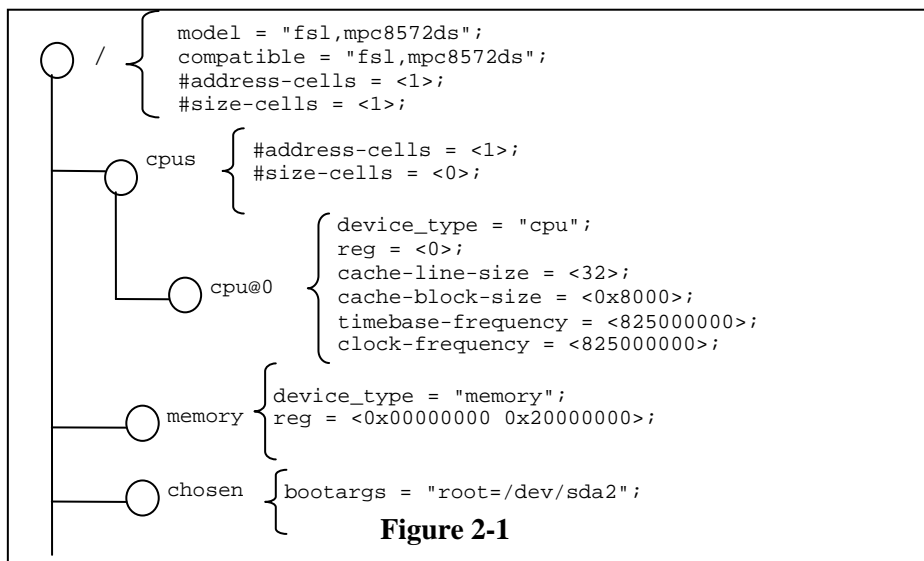

Figure 2-1

1 **2.2 Device Tree Structure and Conventions**

2 **2.2.1 Node Names**

3 2.2.1.1 Node Name Requirements

4

5 Each node in the device tree is named according to the following convention:

6

7

8

9 The *node-name* component specifies the name of the node. It shall be 1 to 31 characters in length and
10 consist solely of characters from the set of characters in *Table 2-1*.

11

12

Table 2-1 Characters for node names

| Character | Description |
|-----------|------------------|
| 0-9 | digit |
| a-z | lowercase letter |
| A-Z | uppercase letter |
| , | comma |
| . | period |
| _ | underscore |
| + | plus sign |
| - | dash |

13

14

14 The *node-name* shall start with a lower or uppercase character and should describe the general class of
15 device.

16

17

17 The *unit-address* component of the name is specific to the bus type on which the node sits. It consists
18 of one or more ASCII characters from the set of characters in *Table 2-1*. The unit-address must
19 match the first address specified in the *reg* property of the node. If the node has no *reg* property, the
20 *@* and *unit-address* must be omitted and the *node-name* alone differentiates the node from other nodes
21 at the same level in the tree. The binding for a particular bus may specify additional, more specific
22 requirements for the format of *reg* and the *unit-address*.

23

24

24 The root node does not have a *node-name* or *unit-address*. It is identified by a forward slash (/).

25

26

1 Example

2

3 See the node names examples in *Figure 2-2*.

4

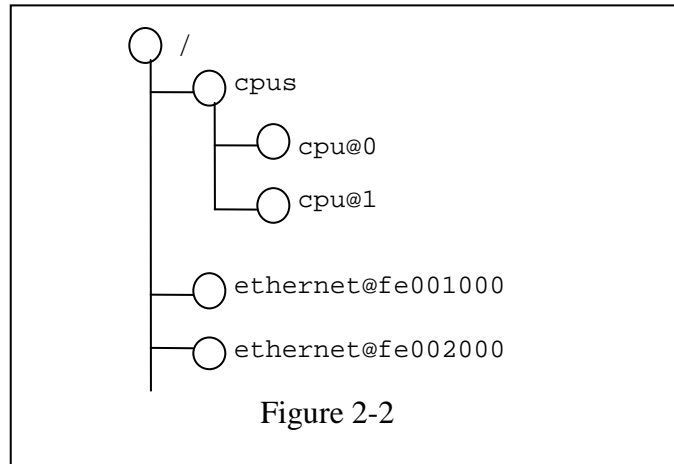

5

6

7

8

In the example:

9

- The nodes with the name `cpu` are distinguished by their *unit-address* values of 0 and 1.
- The nodes with the name `ethernet` are distinguished by their *unit-address* values of FE001000 and FE002000.

10

11

12

13

2.2.2 Generic Names Recommendation

The name of a node should be somewhat generic, reflecting the function of the device and not its precise programming model. If appropriate, the name should be one of the following choices:

- atm
- cache-controller
- compact-flash
- can
- cpu
- crypto
- disk
- display
- dma-controller
- ethernet
- ethernet-phy
- fdc
- flash
- gpio
- i2c
- ide
- interrupt-controller
- isa
- keyboard
- mdio
- memory
- memory-controller
- mouse
- nvram
- parallel
- pc-card
- pci
- pcie
- rtc
- sata
- scsi
- serial
- sound
- spi
- timer
- usb
- vme
- watchdog

2.2.3 Path Names

A node in the device tree can be uniquely identified by specifying the full path from the root node, through all descendant nodes, to the desired node.

The convention for specifying a device path is:

```
/node-name-1/node-name-2/node-name-N
```

For example, in *Figure 2-2* the device path to cpu #1 would be:

```
/cpus/cpu@1
```

The path to the root node is `/`.

A unit address may be omitted if the full path to the node is unambiguous.

If a client program encounters an ambiguous path, its behavior is undefined.

2.2.4 Properties

Each node in the device tree has properties that describe the characteristics of the node. Properties consist of a name and a value.

2.2.4.1 Property Names

Property names are strings of 1 to 31 characters from the following set of characters.

Table 2-2 Characters for property names

| Character | Description |
|-----------|------------------|
| 0-9 | digit |
| a-z | lowercase letter |
| , | comma |
| . | period |
| _ | underscore |
| + | plus sign |
| - | dash |
| ? | question mark |
| # | hash |

Nonstandard property names should specify a unique string prefix, such as a stock ticker symbol, identifying the name of the company or organization that defined the property. Examples:

```
fsl,channel-fifo-len
ibm,ppc-interrupt-server#s
linux,network-index
```

2.2.4.2 Property Values

A property value is an array of zero or more bytes that contain information associated with the property.

Properties might have an empty value if conveying true-false information. In this case, the presence or absence of the property is sufficiently descriptive.

Table 2-3 describes the set of basic value types defined by the ePAPR.

Table 2-3 Property values

| Value | Description |
|---------|--|
| <empty> | Value is empty—used for conveying true-false information, when the presence or absence of the property itself is sufficiently descriptive. |
| <u32> | <p>A 32-bit integer in big-endian format. Example: the 32-bit value 0x11223344 would be represented in memory as:</p> <pre> address 11 address+1 22 address+2 33 address+3 44 </pre> |
| <u64> | <p>Represents a 64-bit integer in big-endian format. Consists of two <u32> values where the first value contains the most significant bits of the integer and the second value contains the least significant bits.</p> <p>Example: the 64-bit value 0x1122334455667788 would be represented as two cells as: <0x11223344 0x55667788>.</p> <p>The value would be represented in memory as:</p> <pre> address 11 address+1 22 address+2 33 address+3 44 address+4 55 address+5 66 address+6 77 address+7 88 </pre> |

1

| | |
|----------------------|---|
| <string> | <p>Strings are printable and null-terminated. Example: the string “hello” would be represented in memory as:</p> <pre> address 68 address+1 65 address+2 6C address+3 6C address+4 6F address+5 00 </pre> |
| <prop-encoded-array> | Format is specific to the property. See the property definition. |
| <phandle> | A <u32> value. A <i>phandle</i> value is a way to reference another node in the device tree. Any node that can be referenced defines a <i>phandle</i> property with a unique <u32> value. That unique number is specified for the value of properties with a <i>phandle</i> value type. |
| <stringlist> | <p>A list of <string> values concatenated together. Example: The string list “hello”; “world” would be represented in memory as:</p> <pre> address 68 address+1 65 address+2 6C address+3 6C address+4 6F address+5 00 address+6 77 address+7 6F address+8 72 address+9 6C address+10 64 address+11 00 </pre> |

2

3

4

2.3 Standard Properties

The ePAPR specifies a set of standard properties for device nodes. These properties are described in detail in this section. Device nodes defined by the ePAPR (see *Chapter 3, Device Node Requirements*) may specify additional requirements or constraints regarding the use of the standard properties. Device bindings (*Chapter 6*) that describe the representation of specific devices may also specify additional requirements.

Note: All examples of device tree nodes in this document use the Device Tree Source (DTS) format for specifying nodes and properties.

2.3.1 compatible

Property: *compatible*

Value type: *<stringlist>*

Description:

The *compatible* property value consists of one or more strings that define the specific programming model for the device. This list of strings should be used by a client program for device driver selection. The property value consists of a concatenated list of null terminated strings, from most specific to most general. They allow a device to express its compatibility with a family of similar devices, potentially allowing a single device driver to match against several devices.

The recommended format is “*manufacturer , model*”, where *manufacturer* is a string describing the name of the manufacturer (such as a stock ticker symbol), and *model* specifies the model number.

Example:

```
compatible = "fsl,mpc8641-uart", "ns16550";
```

In this example, an operating system would first try to locate a device driver that supported *fsl,mpc8641-uart*. If a driver was not found, it would then try to locate a driver that supported the more general *ns16550* device type.

2.3.2 model

Property: *model*

Value type: *<string>*

Description:

The *model* property value is a *<string>* that specifies the manufacturer’s model number of the device.

The recommended format is: “*manufacturer , model*”, where *manufacturer* is a string describing the name of the manufacturer (such as a stock ticker symbol), and *model* specifies the model number.

1 Example:

```
2     model = "fsl,MPC8349EMITX";  
3
```

4 **2.3.3 phandle**

5
6 Property: *phandle*

7 Value type: <u32>

8 Description:

9 The *phandle* property specifies a numerical identifier for a node that is unique within the
10 device tree. The *phandle* property value is used by other nodes that need to refer to the node
11 associated with the property.

12

13 Example:

14

15 See the following device tree excerpt:

16

```
17         pic@10000000 {  
18             phandle = <1>;  
19             interrupt-controller;  
20         };
```

21

22 A phandle value of 1 is defined. Another device node could reference the *pic* node with a
23 phandle value of 1:

24

```
25         interrupt-parent = <1>;
```

26

27

Compatibility Note

Older versions of device trees may be encountered that contain a deprecated form of this property called `linux,phandle`. For compatibility, a client program might want to support `linux,phandle` if a `phandle` property is not present. The meaning and use of the two properties is identical.

28

Programming Note

Most device trees in *Device Tree Syntax (DTS)* (see Appendix A) will not contain explicit `phandle` properties. The DTC tool automatically inserts the *phandle* properties when the DTS is compiled into the binary DTB format.

29

30

31

1 **2.3.4 status**

2 Property: *status*

3 Value type: *<string>*

4 Description:

5 The status property indicates the operational status of a device. Valid values are listed and
6 defined in the following table.

7

8

Table 2-4 Values for status property

| Value | Description |
|------------|---|
| "okay" | Indicates the device is operational |
| "disabled" | Indicates that the device is not presently operational, but it might become operational in the future (for example, something is not plugged in, or switched off). Refer to the device binding for details on what <i>disabled</i> means for a given device. |
| "fail" | Indicates that the device is not operational. A serious error was detected in the device, and it is unlikely to become operational without repair. |
| "fail-sss" | Indicates that the device is not operational. A serious error was detected in the device and it is unlikely to become operational without repair. The <i>sss</i> portion of the value is specific to the device and indicates the error condition detected. |

9

10

2.3.5 #address-cells and #size-cells

Property: *#address-cells*, *#size-cells*

Value type: `<u32>`

Description:

The *#address-cells* and *#size-cells* properties may be used in any device node that has children in the device tree hierarchy and describes how child device nodes should be addressed. The *#address-cells* property defines the number of `<u32>` cells used to encode the address field in a child node's *reg* property. The *#size-cells* property defines the number of `<u32>` cells used to encode the size field in a child node's *reg* property.

The *#address-cells* and *#size-cells* properties are not inherited from ancestors in the device tree. They shall be explicitly defined.

An ePAPR-compliant boot program shall supply *#address-cells* and *#size-cells* on all nodes that have children.

If missing, a client program should assume a default value of 2 for *#address-cells*, and a value of 1 for *#size-cells*.

Example

See the device tree fragment shown in *Figure 2-3*.

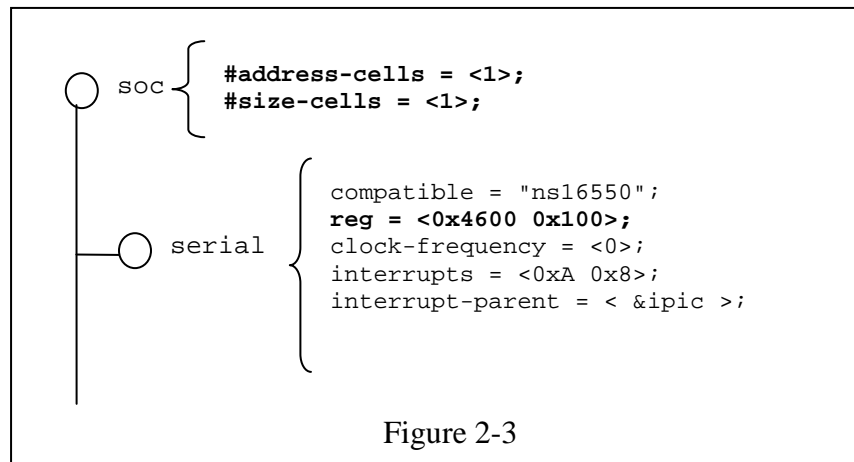

In *Figure 2-3*, the *#address-cells* and *#size-cells* properties of the `soc` node are both set to 1. This setting specifies that one cell is required to represent an address and one cell is required to represent the size of nodes that are children of this node.

The serial device *reg* property necessarily follows this specification set in the parent (`soc`) node—the address is represented by a single cell (0x4600), and the size is represented by a single cell (0x100).

1 **2.3.6 reg**

2
3 Property: *reg*

4 Value type: *<prop-encoded-array>* encoded as arbitrary number of (address,length) pairs.

5 Description:

6 The *reg* property describes the address of the device's resources within the address space defined by
7 its parent bus. Most commonly this means the offsets and lengths of memory-mapped IO register
8 blocks, but may have a different meaning on some bus types. Addresses in the address space defined
9 by root node are cpu real addresses.

10
11 The value is a *<prop-encoded-array>*, composed of an arbitrary number of pairs of address
12 and length, *<address length>*. The number of *<u32>* cells required to specify the address
13 and length are bus-specific and are specified by the *#address-cells* and *#size-cells* properties
14 in the parent of the device node. If the parent node specifies a value of 0 for *#size-cells*, the
15 length field in the value of *reg* shall be omitted.

16
17 Example:

18 Suppose a device within a system-on-a-chip had two blocks of registers—a 32-byte block at
19 offset 0x3000 in the SOC and a 256-byte block at offset 0xFE00. The *reg* property would be
20 encoded as follows (assuming *#address-cells* and *#size-cells* values of 1):

21
22 `reg = <0x3000 0x20 0xFE00 0x100>;`
23

24 **2.3.7 virtual-reg**

25 Property: *virtual-reg*

26 Value type: *<u32>*

27 Description:

28 The *virtual-reg* property specifies an effective address that maps to the first physical address
29 specified in the *reg* property of the device node. This property enables boot programs to
30 provide client programs with virtual-to-physical mappings that have been set up.

1 2.3.8 ranges

2
3 Property: *ranges*

4 Value type: *<empty>* or *<prop-encoded-array>* encoded as arbitrary number of triplets of (*child-bus-*
5 *address, parent-bus-address, length*).

6 Description:

7 The *ranges* property provides a means of defining a mapping or translation between the
8 address space of the bus (the child address space) and the address space of the bus node's
9 parent (the parent address space).

10
11 The format of the value of the *ranges* property is an arbitrary number of triplets of (*child-bus-*
12 *address, parent-bus-address, length*)

- 13
14 • The *child-bus-address* is a physical address within the child bus' address space. The
15 number of cells to represent the address is bus dependent and can be determined from
16 the *#address-cells* of *this* node (the node in which the *ranges* property appears).
- 17
18 • The *parent-bus-address* is a physical address within the parent bus' address space.
19 The number of cells to represent the parent address is bus dependent and can be
20 determined from the *#address-cells* property of the node that defines the parent's
21 address space.
- 22
23 • The *length* specifies the size of the range in the child's address space. The number of
24 cells to represent the size can be determined from the *#size-cells* of *this* node (the
25 node in which the *ranges* property appears).

26
27 If the property is defined with an *<empty>* value, it specifies that the parent and child address
28 space is identical, and no address translation is required.

29
30 If the property is not present in a bus node, it is assumed that no mapping exists between
31 children of the node and the parent address space.

1
2

See the example in Figure 2-4.

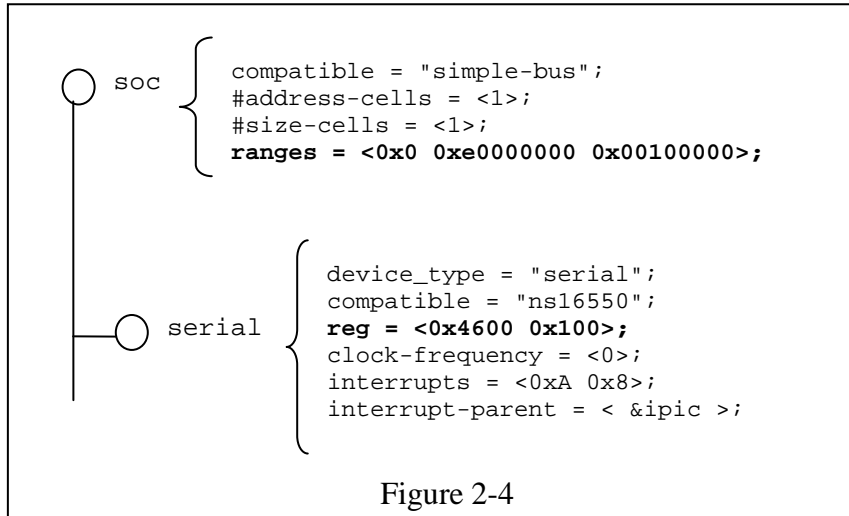
3
4
5
6
7
8
9
10
11
12
13
14
15In Figure 2-4 , the `soc` node specifies a `ranges` property of

```
<0x0 0xe0000000 0x00100000>;
```

This property value specifies that for an 1024KB range of address space, a child node addressed at physical `0x0` maps to a parent address of physical `0xe0000000`. With this mapping, the `serial` device node can be addressed by a load or store at address `0xe0004600`, an offset of `0x4600` (specified in `reg`) plus the `0xe0000000` mapping specified in `ranges`.

2.3.9 dma-ranges

Property: *dma-ranges*

Value type: <empty> or <prop-encoded-array> encoded as arbitrary number of triplets of (*child-bus-address*, *parent-bus-address*, *length*).

Description:

The *dma-ranges* property is used to describe the direct memory access (DMA) structure of a memory-mapped bus whose device tree parent can be accessed from DMA operations originating from the bus. It provides a means of defining a mapping or translation between the physical address space of the bus and the physical address space of the parent of the bus.

The format of the value of the *dma-ranges* property is an arbitrary number of triplets of (*child-bus-address*, *parent-bus-address*, *length*). Each triplet specified describes a contiguous DMA address range.

- The *child-bus-address* is a physical address within the child bus' address space. The number of cells to represent the address depends on the bus and can be determined from the *#address-cells* of *this* node (the node in which the *dma-ranges* property appears).
- The *parent-bus-address* is a physical address within the parent bus' address space. The number of cells to represent the parent address is bus dependent and can be determined from the *#address-cells* property of the node that defines the parent's address space.
- The *length* specifies the size of the range in the child's address space. The number of cells to represent the size can be determined from the *#size-cells* of *this* node (the node in which the *dma-ranges* property appears).

1 2.3.10 name

2

Compatibility NoteProperty: *name*Value type: *<string>*

Description:

The *name* property is a string specifying the name of the node. This property is deprecated, and its use is not recommended. However, it might be used in older non-ePAPR-compliant device trees.

Operating system should determine a node's name based on the *name* component of the node name (see section 2.2.1).

3

4 2.3.11 device_type

5

6 Property: *device_type*7 Value type: *<string>*

8 Description:

9 The *device_type* property was used in IEEE 1275 to describe the device's FCode
10 programming model. Because ePAPR does not have FCode, new use of the property is
11 deprecated, and it should be included only on cpu and memory nodes for compatibility with
12 IEEE 1275-derived device trees.

13

2.4 Interrupts and Interrupt Mapping

The ePAPR adopts the interrupt tree model of representing interrupts specified in *Open Firmware Recommended Practice: Interrupt Mapping, Version 0.9* [7]. Within the device tree a logical interrupt tree exists that represents the hierarchy and routing of interrupts in the platform hardware. While generically referred to as an *interrupt tree* it is more technically a directed acyclic graph.

The physical wiring of an interrupt source to an interrupt controller is represented in the device tree with the *interrupt-parent* property. Nodes that represent interrupt-generating devices contain an *interrupt-parent* property which has a *phandle* value that points to the device to which the device's interrupts are routed, typically an interrupt controller. If an interrupt-generating device does not have an *interrupt-parent* property, its interrupt parent is assumed to be its device tree parent.

Each interrupt generating device contains an *interrupts* property with a value describing one or more interrupt sources for that device—each source represented with information called an *interrupt specifier*. The format and meaning of an *interrupt specifier* is interrupt domain specific, i.e., it is dependent on properties on the node at the root of its interrupt domain. The *#interrupt-cells* property is used by the root of an interrupt domain to define the number of <u32> values needed to encode an interrupt specifier. For example, for an Open PIC interrupt controller, an interrupt-specifier takes two 32-bit values and consists of an interrupt number and level/sense information for the interrupt.

An interrupt domain is the context in which an interrupt specifier is interpreted. The root of the domain is either (1) an interrupt controller or (2) an interrupt *nexus*.

1. An *interrupt controller* is physical device and will need a driver to handle interrupts routed through it. It may also cascade into another interrupt domain. An interrupt controller is specified by the presence of an *interrupt-controller* property on that node in the device tree.
2. An *interrupt nexus* defines a translation between one interrupt domain and another. The translation is based on both domain-specific and bus-specific information. This translation between domains is performed with the *interrupt-map* property. For example, a PCI controller device node could be an interrupt nexus that defines a translation from the PCI interrupt *namespace* (INTA, INTB, etc.) to an interrupt controller with Interrupt Request (IRQ) numbers.

The root of the interrupt tree is determined when traversal of the interrupt tree reaches an interrupt controller node without an *interrupts* property and thus no explicit interrupt parent.

1 See Figure 2-5 for an example of a graphical representation of a device tree with interrupt parent
2 relationships shown. Figure 2-6 shows the corresponding interrupt tree.
3

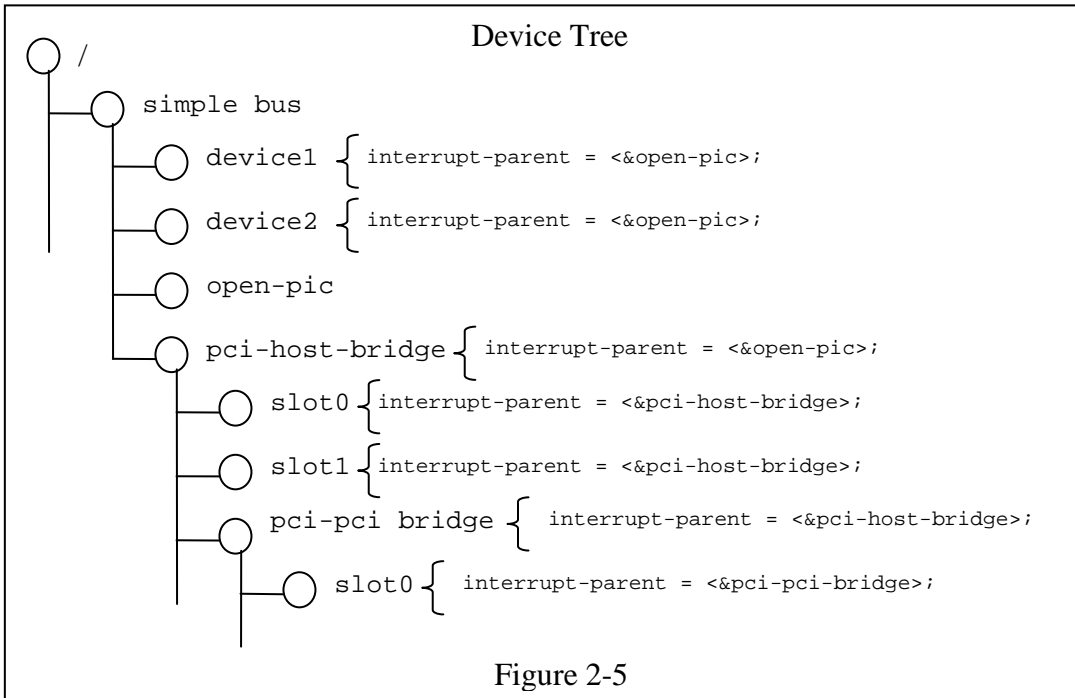

4
5

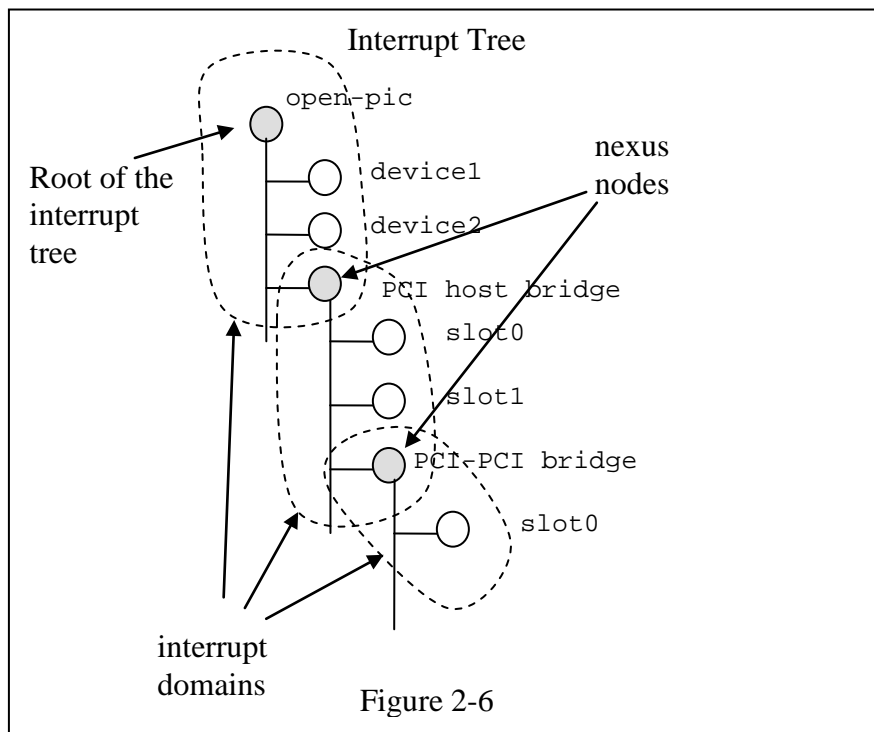

6
7

1 In the example shown in Figure 2-5 and Figure 2-6 :

- 2 • The `open-pic` interrupt controller is the root of the interrupt tree.
- 3 • The interrupt tree root has three children—devices that route their interrupts directly to the
- 4 `open-pic`
 - 5 o `device1`
 - 6 o `device2`
 - 7 o `PCI bus controller`
- 8 • Three interrupt domains exist—one rooted at the `open-pic` node, one at the `PCI host`
- 9 `bridge` node, and one at the `PCI-PCI bridge` node.
- 10 • There are two nexus nodes— one at the `PCI host bridge` and one at the `PCI-PCI`
- 11 `bridge`

12 2.4.1 Properties for Interrupt Generating Devices

13 2.4.1.1 interrupts

14 Property: *interrupts*

15 Value type: *<prop-encoded-array>* encoded as arbitrary number of interrupt specifiers

16 Description:

17 The *interrupts* property of a device node defines the interrupt or interrupts that are generated

18 by the device. The value of the *interrupts* property consists of an arbitrary number of interrupt

19 specifiers. The format of an interrupt specifier is defined by the binding of the interrupt

20 domain root.

21

22

23 Example:

24 A common definition of an interrupt specifier in an open PIC-compatible interrupt domain

25 consists of two cells—an interrupt number and level/sense information. See the following

26 example, which defines a single interrupt specifier, with an interrupt number of `0xA` and

27 level/sense encoding of `8`.

28

29

```
interrupts = <0xA 8>;
```

30 2.4.1.2 interrupt-parent

31 Property: *interrupt-parent*

32 Value type: *<phandle>*

33 Description:

34 Because the hierarchy of the nodes in the interrupt tree might not match the device tree, the

35 *interrupt-parent* property is available to make the definition of an interrupt parent explicit.

36 The value is the *phandle* to the interrupt parent. If this property is missing from a device, its

37 interrupt parent is assumed to be its device tree parent.

38

39

1 2.4.2 Properties for Interrupt Controllers

2 2.4.2.1 #interrupt-cells

3

4 Property: *#interrupt-cells*

5 Value type: <u32>

6 Description:

7 The *#interrupt-cells* property defines the number of cells required to encode an interrupt
8 specifier for an interrupt domain.

9 2.4.2.2 interrupt-controller

10

11 Property: *interrupt-controller*

12 Value type: <empty>

13 Description:

14 The presence of an *interrupt-controller* property defines a node as an interrupt controller node.
15

16 2.4.3 Interrupt Nexus Properties

17

18 An interrupt nexus node shall have an *#interrupt-cells* property.

19 2.4.3.1 interrupt-map

20

21 Property: *interrupt-map*

22 Value type: <prop-encoded-array> encoded as an arbitrary number of interrupt mapping entries.

23 Description:

24 An *interrupt-map* is a property on a nexus node that bridges one interrupt domain with a set
25 of parent interrupt domains and specifies how interrupt specifiers in the child domain are
26 mapped to their respective parent domains.

27

28 The interrupt map is a table where each row is a mapping entry consisting of five
29 components: *child unit address*, *child interrupt specifier*, *interrupt-parent*, *parent unit*
30 *address*, *parent interrupt specifier*.

31

- 32 • **child unit address**. The unit address of the child node being mapped. The number of
33 32-bit cells required to specify this is described by the *#address-cells* property of the
34 bus node on which the child is located.
- 35
- 36 • **child interrupt specifier**. The interrupt specifier of the child node being mapped.
37 The number of 32-bit cells required to specify this component is described by the
38 *#interrupt-cells* property of this node—the nexus node containing the *interrupt-map*
39 property.
- 40
- 41 • **interrupt-parent** . A single <phandle> value that points to the interrupt parent to
42 which the child domain is being mapped.

-
- 1
 - 2 • **parent unit address.** The unit address in the domain of the interrupt parent. The
 - 3 number of 32-bit cells required to specify this address is described by the *#address-*
 - 4 *cells* property of the node pointed to by the *interrupt-parent* field.
 - 5
 - 6 • **parent interrupt specifier.** The interrupt specifier in the parent domain. The number
 - 7 of 32-bit cells required to specify this component is described by the *#interrupt-cells*
 - 8 property of this node—the nexus node containing the *interrupt-map* property.
 - 9

10 Lookups are performed on the interrupt mapping table by matching a unit-address/interrupt
 11 specifier pair against the child components in the *interrupt-map*. Because some fields in the
 12 unit interrupt specifier may not be relevant, a mask is applied before the lookup is done. This
 13 mask is defined in the *interrupt-map-mask* property (see *section 2.4.3.2*).

14

15 **Note:** Both the child node and the interrupt parent node are required to have *#address-cells*
 16 and *#interrupt-cells* properties defined. If a unit address component is not required,
 17 *#address-cells* shall be explicitly defined to be zero.

18 2.4.3.2 *interrupt-map-mask*

19

20 Property: *interrupt-map-mask*

21 Value type: *<prop-encoded-array>* encoded as a bit mask

22 Description:

23 An *interrupt-map-mask* property is specified for a nexus node in the interrupt tree. This
 24 property specifies a mask that is applied to the incoming unit interrupt specifier being looked
 25 up in the table specified in the *interrupt-map* property.

26 2.4.3.3 *#interrupts-cells*

27

28 Property: *#interrupts-cells*

29 Value type: *<u32>*

30 Description:

31 The *#interrupt-cells* property defines the number of cells required to encode an interrupt
 32 specifier for an interrupt domain.

33

34

2.4.4 Interrupt Mapping Example

Figure 2-7 shows the representation of a fragment of a device tree with a PCI bus controller and a sample interrupt map for describing the interrupt routing for two PCI slots (IDSEL 0x11,0x12). The INTA, INTB, INTC, and INTD pins for slots 1 and 2 are wired to the Open PIC interrupt controller.

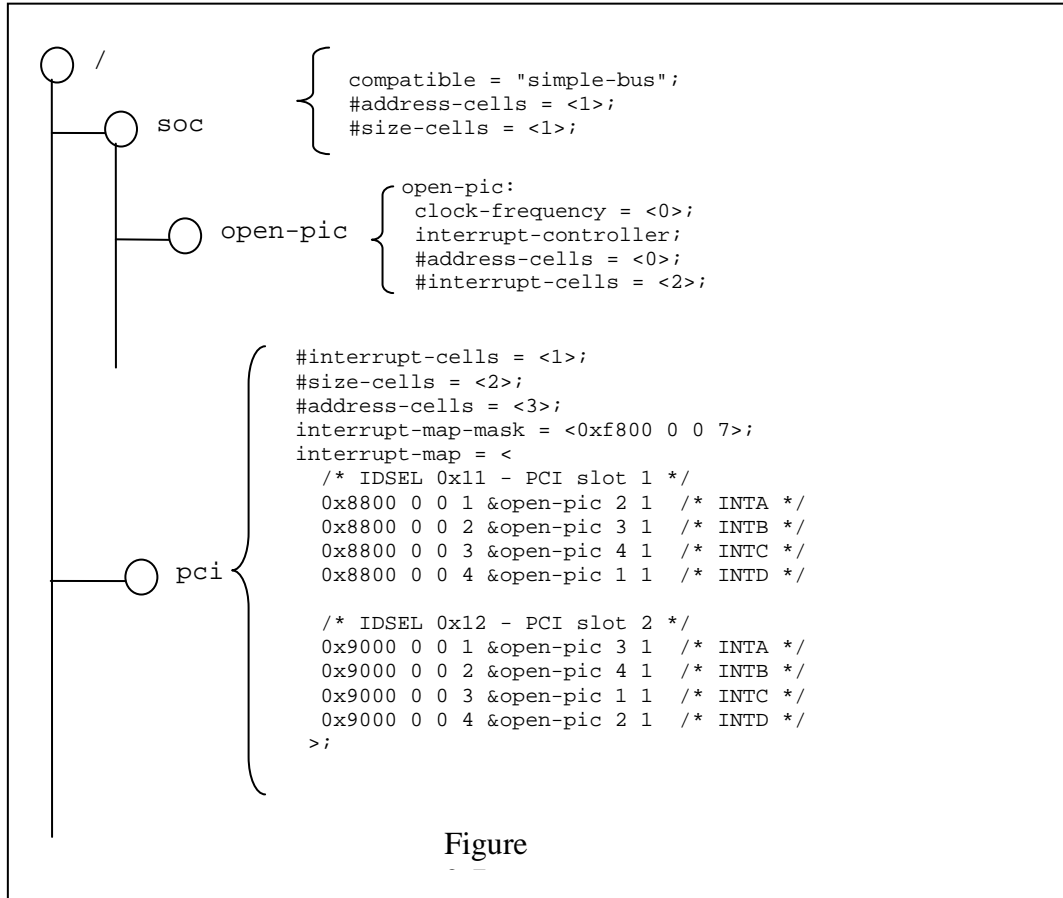

- One Open PIC interrupt controller is represented and is identified as an interrupt controller with an *interrupt-controller* property.
- Each row in the interrupt-map table consists of five parts—a child unit address and interrupt specifier, which is mapped to an *interrupt-parent* node with a specified parent unit address and interrupt specifier.

3 Device Node Requirements

3.1 Base Device Node Types

The sections that follow specify the requirements for the base set of device nodes required in an ePAPR-compliant device tree.

All device trees shall have a root node and the following nodes shall be present at the root of all device trees:

- One *cpus* node
- At least one *memory* node

3.2 Root node

The device tree has a single root node of which all other device nodes are descendants. The full path to the root node is /.

Properties

Table 3-1 Root node properties

| Property Name | Usage | Value Type | Definition |
|---|-------|--------------|---|
| #address-cells | R | <u32> | Specifies the number of <u32> cells to represent the address in the <i>reg</i> property in <i>children</i> of root. |
| #size-cells | R | <u32> | Specifies the number of <u32> cells to represent the size in the <i>reg</i> property in <i>children</i> of root. |
| model | R | <string> | Specifies a string that uniquely identifies the model of the system board. The recommended format is "manufacturer,model-number". |
| compatible | R | <stringlist> | Specifies a list of platform architectures with which this platform is compatible. This property can be used by operating systems in selecting platform specific code. The recommended form of the property value is: " <i><Manufacturer>,<Model-number></i> " For example: <code>compatible = "fsl,mpc8572ds"</code> |
| epapr-version | R | <string> | This property shall contain the string: "ePAPR- <i><ePAPR version></i> " where: <ul style="list-style-type: none"> • <i><ePAPR version></i> is the text (without blanks) after the word <i>Version</i> on the cover page of the PAPR spec that the platform adheres to For example: <code>epapr-version = "ePAPR-1.1"</code> |
| Usage legend: R=Required, O=Optional, OR=Optional but Recommended, SD=See Definition Note: All other standard properties (section 2.3) are allowed but are optional. | | | |

1 **3.3 aliases node**

2
3 A device tree may have an aliases node (`/aliases`) that defines one or more alias properties. The
4 alias node shall be at the root of the device tree and have the node name `aliases`.

5
6 Each property of the `/aliases` node defines an *alias*. The property name specifies the alias name.
7 The property value specifies the full path to a node in the device tree. For example, the property
8 `serial0 = "/simple-bus@fe000000/serial@11c500"` defines the alias *serial0*.

9
10 Alias names shall be a lowercase text strings of 1 to 31 characters from the following set of characters.

11
12 **Table 3-2 Characters for alias names**

| Character | Description |
|-----------|---------------------|
| 0-9 | digit |
| a-z | lowercase character |
| - | dash |

13
14 An alias value is a device path and is encoded as a string. The value represents the full path to a node,
15 but the path does not need to refer to a leaf node.

16
17 A client program may use an alias property name to refer to a full device path as all or part of its string
18 value. A client program, when considering a string as a device path, shall detect and use the alias.

19
20 **Example:**

```
21
22     aliases {
23         serial0 = "/simple-bus@fe000000/serial@11c500";
24         ethernet0 = "/simple-bus@fe000000/ethernet@31c000";
25     }
26
```

27 Given the alias `serial0`, a client program can look at the `/aliases` node and determine the alias
28 refers to the device path `/simple-bus@fe000000/serial@11c500`.

3.4 Memory node

A memory device node is required for all device trees and describes the physical memory layout for the system. If a system has multiple ranges of memory, multiple memory nodes can be created, or the ranges can be specified in the *reg* property of a single memory node.

The name component of the node name (see 2.2.1) shall be *memory*.

The client program may access memory not covered by any memory reservations (see section 8.3) using any storage attributes it chooses. However, before changing the storage attributes used to access a real page, the client program is responsible for performing actions required by the architecture and implementation, possibly including flushing the real page from the caches. The boot program is responsible for ensuring that, without taking any action associated with a change in storage attributes, the client program can safely access all memory (including memory covered by memory reservations) as *WIMG = 0b001x*. That is:

- not Write Through Required
- not Caching Inhibited
- Memory Coherence Required
- either not Guarded or Guarded (i.e., *WIMG = 0b001x*)

If the VLE storage attribute is supported, with *VLE=0*.

Properties

Table 3-3 Memory node properties

| Property Name | Usage | Value Type | Definition |
|---|-------|----------------------|--|
| <i>device_type</i> | R | <string> | Value shall be “memory”. |
| <i>reg</i> | R | <prop-encoded-array> | Consists of an arbitrary number of address and size pairs that specify the physical address and size of the memory ranges. |
| <i>initial-mapped-area</i> | O | <prop-encoded-array> | Specifies the address and size of the Initial Mapped Area (see section 5.3). Is a prop-encoded-array consisting of a triplet of (<i>effective address</i> , <i>physical address</i> , <i>size</i>). The effective and physical address shall each be 64-bit (<u64> value), and the size shall be 32-bits (<u32> value). |
| Usage legend: R=Required, O=Optional, OR=Optional but Recommended, SD=See Definition Note: All other standard properties (section 2.3) are allowed but are optional. | | | |

Example

Given a 64-bit Power system with the following physical memory layout:

- RAM: starting address 0x0, length 0x80000000 (2GB)
- RAM: starting address 0x100000000, length 0x100000000 (4GB)

Memory nodes could be defined as follows, assuming an *#address-cells* value of 2 and a *#size-cells* value of 2:

Example #1

```

1  memory@0 {
2
3      device_type = "memory";
4      reg = <0x000000000 0x00000000 0x00000000 0x80000000
5          0x000000001 0x00000000 0x00000001 0x00000000>;
6
7  };
8

```

Example #2

```

9
10
11  memory@0 {
12      device_type = "memory";
13      reg = <0x000000000 0x00000000 0x00000000 0x80000000>;
14
15  };
16
17  memory@100000000 {
18      device_type = "memory";
19      reg = <0x000000001 0x00000000 0x00000001 0x00000000>;
20
21  };
22

```

The *reg* property is used to define the address and size of the two memory ranges. The 2 GB I/O region is skipped. Note that the *#address-cells* and *#size-cells* properties of the root node specify a value of 2, which means that two 32-bit cells are required to define the address and length for the *reg* property of the memory node.

3.5 Chosen

The *chosen* node does not represent a real device in the system but describes parameters chosen or specified by the system firmware at run time. It shall be a child of the root node.

The node name (see 2.2.1) shall be *chosen*.

Properties

Table 3-4 Chosen node properties

| Property Name | Usage | Value Type | Definition |
|---------------|-------|------------|---|
| bootargs | O | <string> | A string that specifies the boot arguments for the client program. The value could potentially be a null string if no boot arguments are required. |
| stdout-path | O | <string> | A string that specifies the full path to the node representing the device to be used for boot console output. If the character ":" is present in the value it terminates the path. The value may be an alias. If the stdin-path property is not specified, stdout-path should be assumed to define the input device. |
| stdin-path | O | <string> | A string that specifies the full path to the node representing the device to be used for boot console input. If the character ":" is present in the value it terminates the path. The value may be an alias. |

Usage legend: R=Required, O=Optional, OR=Optional but Recommended, SD=See Definition

Note: All other standard properties (section 2.3) are allowed but are optional.

Example1
2
3
4
5
6

```
chosen {
    bootargs = "root=/dev/nfs rw nfsroot=192.168.1.1 console=ttyS0,115200";
};
```

Compatibility Note

Older versions of device trees may be encountered that contain a deprecated form of the *stdout-path* property called *linux,stdout-path*. For compatibility, a client program might want to support *linux,stdout-path* if a *stdout-path* property is not present. The meaning and use of the two properties is identical.

7

3.6 CPUS Node Properties8
9

A *cpus* node is required for all device trees. It does not represent a real device in the system, but acts as a container for child *cpu* nodes which represent the systems CPUs.

The node name (see 2.2.1) shall be *cpus*.

Properties10
11
12
13
14
15
16Table 3-5 *cpus* node properties

| Property Name | Usage | Value Type | Definition |
|---|-------|------------|--|
| #address-cells | R | <u32> | The value specifies how many cells each element of the <i>reg</i> property array takes in children of this node. |
| #size-cells | R | <u32> | Value shall be 0. Specifies that no size is required in the <i>reg</i> property in children of this node. |
| Usage legend: R=Required, O=Optional, OR=Optional but Recommended, SD=See Definition Note: All other standard properties (section 2.3) are allowed but are optional. | | | |

The *cpus* node may contain properties that are common across CPU nodes. See section 3.7 for details.

For an example, see section 3.7.4.

3.7 CPU Node Properties

A *cpu* node represents a hardware execution block that is sufficiently independent that it is capable of running an operating system without interfering with other CPUs possibly running other operating systems.

Hardware threads that share an MMU would generally be represented under one *cpu* node. If other more complex CPU topographies are designed, the binding for the CPU must describe the topography (e.g. threads that don't share an MMU).

17
18
19
20
21
22
23
24
25
26
27
28
29
30

1 CPUs and threads are numbered through a unified number-space that should match as closely as
 2 possible the interrupt controller's numbering of CPUs/threads.

3
 4 Properties that have identical values across CPU nodes may be placed in the *cpus* node instead. A
 5 client program must first examine a specific CPU node, but if an expected property is not found then it
 6 should look at the parent *cpus* node. This results in a less verbose representation of properties which
 7 are identical across all CPUs.

8
 9 The node name for every cpu node (see 2.2.1) should be *cpu*.

10 3.7.1 General Properties of CPU nodes

11 The following table describes the general properties of CPU nodes. Some of the properties described
 12 in *Table 3-6* are select standard properties with specific applicable detail.

13
 14 **Table 3-6 cpu node general properties**

| Property Name | Usage | Value Type | Definition |
|--------------------------|-------|------------------------------|--|
| device_type | R | <string> | Value shall be "cpu". |
| reg | R | <prop- encoded- array> | <p>The value of "reg" is a <prop-encoded-array> that defines a unique CPU/thread id for the CPU/threads represented by the CPU node.</p> <p>If a CPU supports more than one thread (i.e. multiple streams of execution) the <i>reg</i> property is an array with 1 element per thread. The <i>#address-cells</i> on the <i>/cpus</i> node specifies how many cells each element of the array takes. Software can determine the number of threads by dividing the size of <i>reg</i> by the parent node's <i>#address-cells</i>.</p> <p>If a CPU/thread can be the target of an external interrupt the "reg" property value must be a unique CPU/thread id that is addressable by the interrupt controller.</p> <p>If a CPU/thread cannot be the target of an external interrupt, then "reg" must be unique and out of bounds of the range addressed by the interrupt controller</p> <p>If a CPU/thread's PIR is modifiable, a client program should modify PIR to match the "reg" property value. If PIR cannot be modified and the PIR value is distinct from the interrupt controller numberspace, the CPUs binding may define a binding-specific representation of PIR values if desired.</p> |
| clock-frequency | R | <prop- encoded- array> | <p>Specifies the current clock speed of the CPU in Hertz. The value is a <prop-encoded-array> in one of two forms:</p> <ol style="list-style-type: none"> 1. A 32-bit integer consisting of one <u32> specifying the frequency. 2. A 64-bit integer represented as a <u64> specifying the frequency. |
| timebase-frequency | R | <prop- encoded- array> | <p>Specifies the current frequency at which the timebase and decremter registers are updated (in Hertz). The value is a <prop-encoded-array> in one of two forms:</p> <ol style="list-style-type: none"> 1. A 32-bit integer consisting of one <u32> specifying the frequency. 2. A 64-bit integer represented as a <u64>. |
| cache-op-block-size | SD | <u32> | Specifies the block size in bytes upon which cache block instructions operate (e.g., <i>dcbz</i>). Required if different than the L1 cache block size. |
| reservation-granule-size | SD | <u32> | Specifies the reservation granule size supported by this processor in |

| | | | |
|-------------------|----|--------------|---|
| | | | bytes. |
| status | SD | <string> | <p>A standard property describing the state of a CPU. This property shall be present for nodes representing CPUs in a symmetric multiprocessing (SMP) configuration. For a CPU node the meaning of the “okay” and “disabled” values are as follows:</p> <ul style="list-style-type: none"> • “okay”. The CPU is running. • “disabled”. The CPU is in a quiescent state. A quiescent CPU is in a state where it cannot interfere with the normal operation of other CPUs, nor can its state be affected by the normal operation of other running CPUs, except by an explicit method for enabling or reenabling the quiescent CPU (see the <i>enable-method</i> property). <p>In particular, a running CPU shall be able to issue broadcast TLB invalidates without affecting a quiescent CPU. Examples: A quiescent CPU could be in a spin loop, held in reset, and electrically isolated from the system bus or in another implementation dependent state.</p> <p>Note: See section 5.5 (<i>Symmetric Multiprocessing (SMP) Boot Requirements</i>) for a description of how these values are used for booting multi-CPU SMP systems.</p> |
| enable-method | SD | <stringlist> | <p>Describes the method by which a CPU in a disabled state is enabled. This property is required for CPUs with a status property with a value of “disabled”. The value consists of one or more strings that define the method to release this CPU. If a client program recognizes any of the methods, it may use it. The value shall be one of the following:</p> <ul style="list-style-type: none"> • "spin-table" The CPU is enabled with the spin table method defined in the ePAPR. • "[vendor],[method]" An implementation-dependent string that describes the method by which a CPU is released from a "disabled" state. The required format is: vendor,method., where vendor is a string describing the name of the manufacturer and method is a string describing the vendor-specific mechanism. <p>Example: "fsl,MPC8572DS"</p> <p>Note: Other methods may be added to later revisions of the ePAPR specification.</p> |
| cpu-release-addr | SD | <u64> | <p>The <i>cpu-release-addr</i> property is required for cpu nodes that have an enable-method property value of "spin-table". The value specifies the <i>physical</i> address of a spin table entry that releases a secondary CPU from its spin loop.</p> <p>See section 5.5.2, <i>Spin Table</i> or details on the structure of a spin table.</p> |
| power-isa-version | O | <string> | <p>A string that specifies the numerical portion of the Power ISA version string. For example, for an implementation complying with Power ISA Version 2.06, the value of this property would be "2.06".</p> |
| power-isa-* | O | <empty> | <p>If the <i>power-isa-version</i> property exists, then for each category from the Categories section of Book I of the Power ISA version indicated, the existence of a property named <i>power-isa-[CAT]</i>, where [CAT] is the abbreviated category name with all uppercase letters converted to lowercase, indicates that the category is supported by the implementation.</p> <p>For example, if the <i>power-isa-version</i> property exists and its value is "2.06" and the <i>power-isa-e.hv</i> property exists, then the implementation supports [Category:Embedded.Hypervisor] as defined in Power ISA Version 2.06.</p> |

| | | | |
|---|---|----------|--|
| mmu-type | O | <string> | Specifies the CPU's MMU type. Valid values are shown below: "mpc8xx" "ppc40x" "ppc440" "ppc476" "power-embedded" "powerpc-classic" "power-server-stab" "power-server-slb" "none" |
| Usage legend: R=Required, O=Optional, OR=Optional but Recommended, SD=See Definition Note: All other standard properties (section 2.3) are allowed but are optional. | | | |

1

Compatibility Note

Older versions of device trees may be encountered that contain a *bus-frequency* property on CPU nodes. For compatibility, a client-program might want to support *bus-frequency*. The format of the value is identical to that of *clock-frequency*. The recommended practice is to represent the frequency of a bus on the bus node using a *clock-frequency* property.

2

3.7.2 TLB Properties

3

4

5

6

7

8

The following properties of a `cpu` node describe the translate look-aside buffer in the processor's MMU.

Table 3-7, `cpu` node TLB properties

| Property Name | Usage | Value Type | Definition |
|---|-------|------------|--|
| tlb-split | SD | <empty> | If present specifies that the TLB has a split configuration, with separate TLBs for instructions and data. If absent, specifies that the TLB has a unified configuration. Required for a CPU with a TLB in a split configuration. |
| tlb-size | SD | <u32> | Specifies the number of entries in the TLB. Required for a CPU with a unified TLB for instruction and data addresses. |
| tlb-sets | SD | <u32> | Specifies the number of associativity sets in the TLB. Required for a CPU with a unified TLB for instruction and data addresses. |
| d-tlb-size | SD | <u32> | Specifies the number of entries in the data TLB. Required for a CPU with a split TLB configuration. |
| d-tlb-sets | SD | <u32> | Specifies the number of associativity sets in the data TLB. Required for a CPU with a split TLB configuration. |
| i-tlb-size | SD | <u32> | Specifies the number of entries in the instruction TLB. Required for a CPU with a split TLB configuration. |
| i-tlb-sets | SD | <u32> | Specifies the number of associativity sets in the instruction TLB. Required for a CPU with a split TLB configuration. |
| Usage legend: R=Required, O=Optional, OR=Optional but Recommended, SD=See Definition Note: All other standard properties (section 2.3) are allowed but are optional. | | | |

9

10

3.7.3 Internal (L1) Cache Properties

The following properties of a `cpu` node describe the processor's internal (L1) cache.

Table 3-8 Cache properties

| Property Name | Usage | Value Type | Definition |
|--------------------|-------|------------|---|
| cache-unified | SD | <empty> | If present, specifies the cache has a unified organization. If not present, specifies that the cache has a Harvard architecture with separate caches for instructions and data. |
| cache-size | SD | <u32> | Specifies the size in bytes of a unified cache. Required if the cache is unified (combined instructions and data). |
| cache-sets | SD | <u32> | Specifies the number of associativity sets in a unified cache. Required if the cache is unified (combined instructions and data) |
| cache-block-size | SD | <u32> | Specifies the block size in bytes of a unified cache. Required if the processor has a unified cache (combined instructions and data) |
| cache-line-size | SD | <u32> | Specifies the line size in bytes of a unified cache, if different than the cache block size Required if the processor has a unified cache (combined instructions and data). |
| i-cache-size | SD | <u32> | Specifies the size in bytes of the instruction cache. Required if the <code>cpu</code> has a separate cache for instructions. |
| i-cache-sets | SD | <u32> | Specifies the number of associativity sets in the instruction cache. Required if the <code>cpu</code> has a separate cache for instructions. |
| i-cache-block-size | SD | <u32> | Specifies the block size in bytes of the instruction cache. Required if the <code>cpu</code> has a separate cache for instructions. |
| i-cache-line-size | SD | <u32> | Specifies the line size in bytes of the instruction cache, if different than the cache block size. Required if the <code>cpu</code> has a separate cache for instructions. |
| d-cache-size | SD | <u32> | Specifies the size in bytes of the data cache. Required if the <code>cpu</code> has a separate cache for data. |
| d-cache-sets | SD | <u32> | Specifies the number of associativity sets in the data cache. Required if the <code>cpu</code> has a separate cache for data. |
| d-cache-block-size | SD | <u32> | Specifies the block size in bytes of the data cache. Required if the <code>cpu</code> has a separate cache for data. |
| d-cache-line-size | SD | <u32> | Specifies the line size in bytes of the data cache, if different than the cache block size. Required if the <code>cpu</code> has a separate cache for data. |
| next-level-cache | SD | <phandle> | If present, indicates that another level of cache exists. The value is the phandle of the next level of cache. The phandle value type is fully described in section 2.3.3. |

Usage legend: R=Required, O=Optional, OR=Optional but Recommended, SD=See Definition
 Note: All other standard properties (section 2.3) are allowed but are optional.

Compatibility Note

Older versions of device trees may be encountered that contain a deprecated form of the `next-level-cache` property called `l2-cache`. For compatibility, a client-program may wish to support `l2-cache` if a `next-level-cache` property is not present. The meaning and use of the two properties is identical.

3.7.4 Example

Here is an example of a `cpus` node with one child `cpu` node:

```

cpus {
    #address-cells = <1>;
    #size-cells = <0>;

    cpu@0 {
        device_type = "cpu";
        reg = <0>;
        d-cache-block-size = <32>;        // L1 - 32 bytes
        i-cache-block-size = <32>;        // L1 - 32 bytes
        d-cache-size = <0x8000>;         // L1, 32K
        i-cache-size = <0x8000>;         // L1, 32K
        timebase-frequency = <82500000>; // 82.5 MHz
        clock-frequency = <825000000>;  // 825 MHz
    };
};

```

3.8 Multi-level and Shared Caches

Processors and systems may implement additional levels of cache hierarchy—for example, second-level (L2) or third-level (L3) caches. These caches can potentially be tightly integrated to the CPU or possibly shared between multiple CPUs.

A device node with a compatible value of "cache" describes these types of caches.

The cache node shall define a phandle property, and all `cpu` nodes or cache nodes that are associated with or share the cache each shall contain a `next-level-cache` property that specifies the phandle to the cache node.

A cache node may be represented under a CPU node or any other appropriate location in the device tree.

Multiple-level and shared caches are represented with the properties in Table 3-9. The L1 cache properties are described in Table 3-8.

Table 3-9 Multiple-level and shared cache properties

| Property Name | Usage | Value Type | Definition |
|--|-------|------------|--|
| compatible | R | <string> | A standard property. The value shall include the string "cache" |
| cache-level | R | <u32> | Specifies the level in the cache hierarchy. For example, a level 2 cache has a value of <2>. |
| Usage legend: R=Required, O=Optional, OR=Optional but Recommended, SD=See Definition | | | |
| Note: All other standard properties (section 2.3) are allowed but are optional. | | | |

1 Example

2
3 See the following example of a device tree representation of two CPUs, each with their own on-chip
4 L2 and a shared L3.

```

5
6     cpus {
7         #address-cells = <1>;
8         #size-cells = <0>;
9
10        cpu@0 {
11            device_type = "cpu";
12            reg = <0>;
13            cache-unified;
14            cache-size = <0x8000>;          // L1, 32KB
15            cache-block-size = <32>;
16            timebase-frequency = <82500000>; // 82.5 MHz
17            next-level-cache = <&L2_0>;     // phandle to L2
18
19            L2_0:l2-cache {
20                compatible = "cache";
21                cache-unified;
22                cache-size = <0x40000>;    // 256 KB
23                cache-sets = <1024>;
24                cache-block-size = <32>;
25                cache-level = <2>;
26                next-level-cache = <&L3>;   // phandle to L3
27
28                L3:l3-cache {
29                    compatible = "cache";
30                    cache-unified;
31                    cache-size = <0x40000>; // 256 KB
32                    cache-sets = <0x400>;  // 1024
33                    cache-block-size = <32>
34                    cache-level = <3>;
35                };
36            };
37        };
38
39        cpu@1 {
40            device_type = "cpu";
41            reg = <0>;
42            cache-unified;
43            cache-block-size = <32>;
44            cache-size = <0x8000>;          // L1, 32KB
45            timebase-frequency = <82500000>; // 82.5 MHz
46            clock-frequency = <825000000>; // 825 MHz
47            cache-level = <2>;
48            next-level-cache = <&L2_1>;     // phandle to L2
49
50            L2_1:l2-cache {
51                compatible = "cache";
52                cache-unified;
53                cache-size = <0x40000>;    // 256 KB
54                cache-sets = <0x400>;     // 1024
55                cache-line-size = <32>    // 32 bytes
56                next-level-cache = <&L3>;  // phandle to L3
57            };
58        };
59    };
60
61
```

4 Client Program Image Format

This section describes the image format in which an ePAPR client is encoded in order to boot it from an ePAPR-compliant boot program. Two variants on the image format are described: variable-address images and fixed-address images. ePAPR-compliant boot programs shall support client images in the variable-address format, should support images in the fixed-address format, and may also support other formats not described in this document.

4.1 Variable Address Image Format

This ePAPR image format is a constrained form of ELF (*Executable and Linking Format*, see [17]) executable. That is, an ePAPR client image shall be a valid ELF file, but also has additional requirements described in the next sections.

4.1.1 ELF Basics

A variable-address client image is a 32-bit ELF client image with the following ELF header field values:

```
e_ident[EI_CLASS]  ELFCLASS32(0x1)
e_ident[EI_DATA]   ELFDATA2MSB(0x2)
e_type             ET_DYN(0x3)
e_machine          EM_PPC(0x14)
```

That is, it is a 32-bit Power shared-object image in 2's complement, big-endian format.

Every ePAPR image shall have at least one program header of type PT_LOAD. It may also have other valid ELF program headers. The client image shall be arranged so that all its ELF program headers lie within the first 1024 bytes of the image.

4.1.2 Boot Program Requirements

When loading a client image, the boot program need only consider ELF segments of type PT_LOAD. Other segments may be present, but should be ignored by the boot program. In particular, the boot program should not process any ELF relocations found in the client image.

4.1.2.1 Processing of PT_LOAD segments

The boot program shall load the contents of any PT_LOAD segments into RAM, and then pass control to the entry point specified in the ELF header in the manner specified in section 5.4.

Each PT_LOAD segments shall be loaded at an address decided by the boot program, subject to the following constraints.

- The load address shall be congruent with the program header's `p_paddr` value, modulo with the program header's `p_align` value.

- 1 • If there is more than one PT_LOAD segment, then the difference between the loaded address
2 and the address specified in the `p_paddr` field shall be the same for all segments. That is,
3 the boot program shall preserve the relative offsets between PT_LOAD segments by physical
4 address.
5

6 The `p_vaddr` field is reserved to represent the effective address at which the segments will appear
7 after the client program has performed MMU setup. The boot program should not use the program
8 header's `p_vaddr` field for determining the load address of segments.

9 4.1.2.2 Entry point

10 The program entry point is the address of the first instruction that is to be executed in a program image.
11 The ELF header `e_entry` field gives the effective address of the program entry point. However, as
12 described in section 5.4, *CPU Entry Point Requirements*, the client program shall be entered either in
13 real mode or with an initial MMU mapping at effective address 0x0.
14

15 Therefore, the boot program shall compute the physical address of the entry point before entering the
16 client program. To perform this calculation, it shall locate the program segment containing the entry
17 point, determine the difference between `e_entry` and the `p_vaddr` of that segment, and add this
18 difference to the physical address where the segment was loaded.
19

20 This adjusted address will be the physical address of the first client program instruction executed after
21 the boot program jumps to the client program.
22

23 4.1.3 Client Program Requirements

24 The client program is entered with MMU state as described in section 5.4, *CPU Entry Point*
25 *Requirements*. Therefore, the code at the client program's entry point shall be prepared to execute in
26 this environment, which may be different than the MMU environment in which most of the client
27 program executes. The `p_vaddr` fields of the client's ELF program headers will reflect this final
28 environment, not the environment in which the entry point is executed.
29

30 The code at the entry point shall be written so that it can be executed at any address. It shall establish a
31 suitable environment in which the remainder of the client program executes. The ePAPR does not
32 specify its method, but the task could involve:
33

- 34 • Processing ELF relocations to relocate the client's own image to its loaded address. Note that
35 in this case the client image shall be specially linked so that the ELF relocation information,
36 plus any data required to find that information is contained in both the loaded segments and
37 the segments and sections set aside for relocation information.
38 • Processing other tables of relocation information in some format specific to the client
39 program.
40 • Physically copying the client image to the address at which it prefers to execute.
41 • Configuring the MMU so that the client image can execute at its preferred effective address,
42 regardless of the physical address at which it is loaded.
43
44

1 **4.2 Fixed Address Image Format**

2 Fixed-address client images are identical to variable-address client images except for the following
3 changes:

- 4 ○ The `e_type` ELF header field shall have the value `ET_EXEC` (0x2).
- 5 ○ The boot program, instead of loading each `PT_LOAD` segment at an address of its choosing
6 shall load each `PT_LOAD` segment at the physical address given in the program header's
7 `p_paddr` field. If it cannot load the segment at this address (because memory does not exist
8 at that address or is already in use by the boot program itself), then it shall refuse to load the
9 image and report an error condition.

10
11 The fixed-address image format is intended for use by very simple clients (such as diagnostic
12 programs), avoiding the need for such clients to physically relocate themselves to a suitable address.
13 Clients should in general avoid using the fixed-address format, because creating a usable fixed-
14 address image requires knowing which physical areas will be available for client use on the platform
15 in question.
16
17

1 **5 Client Program Boot Requirements**

2 **5.1 Boot and Secondary CPUs**

3
4 A *boot cpu* is the CPU on which control is transferred from the boot program to a client program.
5 Other CPUs that belong to the client program are considered *secondary* CPUs.

6
7 For a partition with multiple CPUs in an SMP configuration, one CPU shall be designated as the boot
8 cpu. The unit address of the CPU node for the boot cpu is set in the `boot_cpuid_phys` field of the
9 flattened device tree header (see section 8.2, *Header*).

10 **5.2 Device Tree**

11
12 A boot program shall load a device tree image into the client program's memory before transferring
13 control to the client on the boot cpu. The logical structure of the device tree shall comply with the
14 requirements specified in section 3.1 (*Base Device Node Types*). The physical structure of the device
15 tree image shall comply with the requirements specified in chapter 8 (*Flat Device Tree Physical*
16 *Structure*).

17
18 The loaded device tree image shall be aligned on an 8-byte boundary in the client's memory.

19 **5.3 Initial Mapped Areas**

20
21 CPUs that implement the Power ISA Book III-E embedded environment, which run with address
22 translation always enabled, have some unique boot requirements related to initial memory mappings.
23 This section introduces the concept of an *Initial Mapped Area* (or *IMA*), which is applicable to Book
24 III-E CPUs.

25
26 A client program's IMA is a region of memory that contains the entry points for a client program.
27 Both boot CPUs and secondary CPUs begin client program execution in an IMA. The terms *Boot IMA*
28 (*BIMA*) and *Secondary IMA* (*SIMA*) are used to distinguish the IMAs for boot CPUs and secondary
29 CPUs where necessary.

30
31 All IMAs have the following requirements:

- 32
33 1. An IMA shall be virtually and physically contiguous
 - 34
35 2. An IMA shall start at effective address zero (0) which shall be mapped to a physical address
36 naturally aligned to the size of the IMA.
 - 37
38 3. The mapping shall not be invalidated except by a client program's explicit action (i.e., not
39 subject to broadcast invalidates from other CPUs)
 - 40
41 4. The Translation ID (TID) field in the TLB entry or entries shall be zero.
 - 42
43 5. The memory and cache access attributes (WIMGE) have the following requirements:
-

-
- WIMG = 001x
 - E=0 (i.e., big-endian)
 - VLE (if implemented) is set to 0
6. An IMA may be mapped by a TLB entry larger than the IMA size, provided the MMU guarded attribute is set (G=1)
 7. An IMA may span multiple TLB entries.

Programming Note

Those CPUs with an IPROT capable TLB should use the IPROT facility to ensure requirement #3.

5.4 CPU Entry Point Requirements

This section describes the state of the processor and system when a boot program passes control to a client program.

5.4.1 Boot CPU Initial Register State

A boot CPU shall have its initial register values set as described in the following table.

Table 5-1 Boot CPU initial register values

| Register | Value |
|----------|--|
| MSR | PR=0 supervisor state EE=0 interrupts disabled ME=0 machine check interrupt disabled IP=0 interrupt prefix-- low memory IR=0,DR=0 real mode (see note 1) IS=0,DS=0 address space 0 (see note 1) SF=0, CM=0, ICM=0 32-bit mode The state of any additional MSR bits is defined in the applicable processor supplement specification. |
| R3 | Effective address of the device tree image. Note: This address shall be 8 bytes aligned in memory. |
| R4 | 0 |
| R5 | 0 |
| R6 | ePAPR magic value—to distinguish from non-ePAPR-compliant firmware <ul style="list-style-type: none"> • For Book III-E CPUs shall be 0x45504150 • For non-Book III-E CPUs shall be 0x65504150 |

| | |
|-----------------|--|
| R7 | shall be the size of the boot IMA in bytes |
| R8 | 0 |
| R9 | 0 |
| TCR | WRC=0, no watchdog timer reset will occur (see note 2) |
| other registers | implementation dependent |

Note 1: Applicable only to CPUs that define these bits

Note 2: Applicable to Book III-E CPUs only

On a multi-threaded processor that supports [Category: Embedded Multi-Threading], the client program shall be entered on thread zero with the register values defined in the preceding table. All other threads shall be disabled and shall have register values set as defined in the preceding table except as follows:

- R3 shall be zero.
- R6 shall be zero.
- R7 shall be zero.
- PC shall be 0x4.

Programming Note

The boot program is expected to place a store instruction at effective address 0x0 and a branch-to-self instruction at effective address 0x4. The store instruction is expected to be used to set a shared variable indicating that the thread has reached the branch-to-self instruction and is ready to be disabled.

5.4.2 I/O Devices State

The boot program shall leave all devices with the following conditions true:

- All devices: no DMA and not interrupting
- Host bridges: responding to config cycles and passing through config cycles to children

5.4.3 Initial I/O Mappings (IIO)

A boot program might pass a client program a device tree containing device nodes with a *virtual-reg* property (see 2.3.7, *virtual-reg*). The *virtual-reg* property describes an *Initial I/O* (or *IIO*) mapping set up by firmware, and the value is the effective address of a device's registers.

For Book III-E CPUs, effective to physical address mappings shall be present in the CPU's MMU to map any IIO. An IIO has the following requirements on Book III-E CPUs:

1. An IIO shall be virtually and physically contiguous.
2. An IIO shall map the effective address in *virtual-reg* to the physical address at which the device appears at the point of entry.

-
- 1 3. An IIO shall not be invalidated except by client's explicit action (i.e., not subject to broadcast
2 invalidates from other partitions).
 - 3
 - 4 4. The Translation ID (TID) field in the TLB entry shall be zero.
 - 5
 - 6 5. The memory and cache access attributes (WIMGE) have the following requirements:
7 • WIMG shall be suitable for accessing the device in question. Typically I=1, G=1.
8 • E=0 (i.e., big-endian)
 - 9
 - 10 6. An IIO shall be large enough to cover all of device's registers.
 - 11
 - 12 7. Multiple devices may share an IIO.

13 **5.4.4 Boot CPU Entry Requirements: Real Mode**

14
15 For real mode (i.e., non-Book III-E) CPUs, the following requirements apply at client entry for boot
16 CPUs:

- 17
- 18 1. The CPU shall have address translation disabled at client entry (i.e., MSR[IR]=0 ,
19 MSR[DR]=0).
- 20
- 21 2. All PT_LOAD segments shall be loaded into an area of memory that is appropriate for the
22 platform.
- 23
- 24 3. The device tree shall be loaded into the an area of memory that is appropriate for the platform
25 (with the address in r3). The device tree must not overlap any PT_LOAD segment (taking
26 into account the p_memsz field in the program header which may be different than
27 p_filesz).
- 28
- 29 4. r7 shall contain the size of the contiguous physical memory available to the client.

30

31 **5.4.5 Boot CPU Entry Requirements for IMAs: Book III-E**

32
33 For Book III-E CPUs the following requirements apply at client entry for boot CPUs:

- 34
- 35 1. The Boot IMA (BIMA) mapping in the MMU shall be mapped at effective address 0.
- 36
- 37 2. All PT_LOAD segments shall be loaded into BIMA.
- 38
- 39 3. The device tree shall be loaded into the BIMA (with the address in r3). The device tree must
40 not overlap any PT_LOAD segment (taking into account the p_memsz field in the program
41 header which may be different than p_filesz).
- 42
- 43 4. IIOs shall be present for all devices with a *virtual-reg* property

- 1
2 5. Other mappings may be present in Address Space (AS) 0.
3
4 6. No mappings shall be present in Address Space (AS) 1.
5
6 7. r7 shall contain the size of the BIMA.
7
8 8. The MMU mappings for the BIMA and all IIOs shall be such that the TLBs can
9 accommodate a reasonable number of additional mappings.
10
11

Programming Notes

- A boot program might wish to select BIMA size based on client image layout in order to satisfy requirement #2
- Client can determine physical address of IMA by either of two methods:
 1. tlbsx on EA 0, then read and parse TLB entry
 2. from the optional *initial-mapped-area* property on a memory node

13

14 **5.5 Symmetric Multiprocessing (SMP) Boot Requirements**15 **5.5.1 Overview**

16

17 For CPUs in an SMP configuration, one CPU shall be designated the boot CPU and initialized as
18 described in section 5.4, *CPU Entry Point Requirements*. All other CPUs are considered *secondary*.

19

20 A boot program passes control to a client program on the boot CPU only. At the time the client
21 program is started, all secondary CPUs shall in a quiescent state. A quiescent CPU is in a state where
22 it cannot interfere with the normal operation of other CPUs, nor can its state be affected by the normal
23 operation of other running CPUs, except by an explicit method for enabling or re-enabling the
24 quiescent CPU. The *status* property of the quiescent CPU's cpu node in the device tree shall have a
25 value of "disabled" (see 3.7.1, *General Properties of CPU nodes*).

26

27 Secondary CPUs may be started using the *spin table* or *implementation-specific* mechanisms
28 described in the following sections.

29

30

1 5.5.2 Spin Table

2 5.5.2.1 Overview

3
4 The ePAPR defines a spin table mechanism for starting secondary CPUs. The boot program places all
5 secondary CPUs into a loop where each CPU spins until the `branch_address` field in the spin
6 table is updated specifying that the core is released.

7
8 A spin table is a table data structure consisting of 1 entry per CPU where each entry is defined as
9 follows:

```
10
11     struct {
12         uint64_t entry_addr;
13         uint64_t r3;
14         uint32_t rsvd1;
15         uint32_t pir;
16     };
17
```

18 The spin table fields are defined as follows:

- 19
- 20 • **entry_addr**. Specifies the physical address of the client entry point for the spin table code to
21 branch to. The boot program's spin loop must wait until the least significant bit of
22 `entry_addr` is zero.
- 23
- 24 • **r3**. Contains the value to put in the `r3` register at secondary cpu entry. The high 32-bits are
25 ignored on 32-bit chip implementations. 64-bit chip implementations however shall load all
26 64-bits
- 27
- 28 • **pir**. Contains a value to load into the PIR (processor identification) register for those CPUs
29 with writable PIR.
- 30

31 Before a secondary CPU enters a spin loop, the spin table fields shall be set with these initial values:

| Field | Initial Value |
|-------------------------|---|
| <code>entry_addr</code> | 0x1 |
| <code>r3</code> | Value of the <code>reg</code> property from the CPU node in the device tree that corresponds to this CPU. |
| <code>pir</code> | A valid PIR value, different on each CPU within the same partition. |

32
33
34
35 The spin table shall be cache-line size aligned in memory.

36
37 The boot program and client program shall ensure that all virtual pages through which the spin table
38 can be accessed have storage control attributes such that all accesses to the spin table are not Write
39 Through Required, not Caching Inhibited, Memory Coherence Required, and either not Guarded or

1 Guarded (i.e., WIMG = 0b001x). Further, if the E storage attribute is supported, it shall be set to Big-
 2 Endian (E = 0), and if the VLE storage attribute is supported, it shall be set to 0.
 3

Programming Note

Some older boot programs perform Caching Inhibited and not Memory Coherence Required accesses to the spin table, taking advantage of implementation-specific knowledge of the behavior of accesses to shared storage with conflicting Caching Inhibited attribute values. If compatibility with such boot programs is required, client programs should use dcbf to flush a spin table entry from the caches both before and after accessing the spin table entry.

5.5.2.2 Boot Program Requirements

4
 5
 6
 7 The boot program shall place a spin loop and spin table into an area of memory that is appropriate for
 8 the platform. If the spin loop and table reside in a memory region belonging to a client program, the
 9 memory occupied by the loop and table shall be marked *reserved* in the device tree's DTB memory
 10 reservation block (see *section 8.3, Memory Reservation Block*).

11
 12 Before starting a client program on the boot cpu, the boot program shall set certain properties in the
 13 device tree passed to the client as follows:

- 14 • Each secondary CPU's cpu node shall have a *status* property with a value of "disabled".
- 15 • Each secondary CPU's cpu node shall have an *enable-method* property.
- 16 • For each secondary cpu node with an *enable-method* value of "spin-table", the cpu node
 17 shall have a *cpu-release-addr* property that describes the address of the applicable spin table
 18 entry to release the CPU.

19
 20 For secondary CPUs with address translation always enabled (e.g., Book III-E), the boot program
 21 shall set up an address mapping in the secondary CPU's MMU for the spin loop and table.
 22

23 The boot program shall place a spinning CPU in a *quiescent* state where it cannot interfere with the
 24 normal operation of other CPUs, nor can its state be affected by the normal operation of other running
 25 CPUs, except by an explicit method for enabling or reenabling the quiescent CPU. (see the *enable-*
 26 *method* property).
 27

28 Note in particular that a running CPU shall be able to issue broadcast TLB invalidations without
 29 affecting a quiescent CPU.
 30

31 When a secondary CPU is released from its spin loop, its state shall be identical to the state of boot
 32 CPUs (see 5.4.1, *Boot CPU Initial Register State*) *except* as noted here:

- 33 • R3 contains the value of the *r3* field from the spin table (only for the first thread of the CPU).
- 34 • R6 shall be 0.
- 35 • If the CPU has a programmable PIR register, the PIR shall contain the value of the *pir* field
 36 from the spin table.
- 37 • No I/O device mappings (see 5.4.3, *Initial I/O Mappings (IIO)*) are required.
- 38 • For CPUs with address translation always enabled:

-
- 1 ○ The Secondary IMA (SIMA) mapping (described in 5.3, *Initial Mapped Areas*) in the
2 MMU shall map effective address 0 to the `entry_addr` field in the spin table,
3 aligned down to the SIMA size.
4 ○ R7 shall contain the size of the SIMA.
5 ○ The SIMA shall have a minimum size of 1MiB.
6 ○ Other mappings may be present in Address Space (AS) 0.
7 ○ No mappings shall be present in Address Space (AS) 1.
8 ○ The MMU mapping for the SIMA shall be such that the TLBs can accommodate a
9 reasonable number of additional mappings.
10 ○ The SIMA mapping shall not be affected by any actions taken by any other CPU.
11 • For real mode (i.e., non-Book III-E) CPUs:
12 ○ The CPU shall have address translation disabled at client entry (i.e., (MSR[IR]=0,
13 MSR[DR]=0).
14 ○ R7 shall contain the size of the contiguous physical memory available to the client.

15
16 Note: Spin table entries do not need to lie in either the BIMA or SIMA.
17
18

Programming Notes

- A client program should physically align its secondary entry points so that the 1MiB SIMA size requirement is sufficient to ensure that enough code is in the SIMA to transfer the secondary CPU to the client's MMU domain (which will typically involve a temporary mapping in AS1)
- Boot programs will typically need to establish the SIMA mapping after leaving the spin loop and reading the `entry_addr` spin table field. However, this mapping might not be necessary if, for example, the boot program always uses a SIMA that covers all RAM.

19

20 5.5.2.3 Client Program Requirements

21

22 When a client program is started on its boot CPU, it is passed a device tree that specifies all secondary
23 CPUs that belong to the client, the state of those CPUs, and the address of the spin table entry to
24 release each CPU.

25

26 For each secondary CPU, the physical address of the spin table entry for the CPU is specified in the
27 device tree in the `cpu` node's `cpu-release-addr` property. To activate a secondary CPU, the client
28 program (running on the boot cpu) may write the `pir` field value, may write the `r3` value, may write
29 the most significant 32 bits of the `entry_addr` value, and shall write the least significant 32 bits of
30 the `entry_addr` value. After the client has written the least significant 32 bits of the `entry_addr`
31 field, the `entry_addr` field might subsequently be altered by the boot program.
32
33

Programming Note

The client program may use a 64-bit store instruction to write both the most significant 32 bits and the least significant 32 bits of the `entry_addr` field atomically. However, since the client program is permitted to use two 32-bit store instructions to write the `entry_addr` field (the first store for the most significant 32 bits and the second store for the least significant 32 bits), the boot program's spin loop must wait until the least significant bit of `entry_addr` is zero (in particular, it is insufficient for the boot program only to wait until `entry_addr` has a value other than 0x1).

1

2 5.5.3 Implementation-Specific Release from Reset

3

4 Some CPUs have implementation-specific mechanisms to hold CPUs in reset (or otherwise inhibit
5 them from executing instructions) and can also direct CPUs to arbitrary reset vectors.

6

7 The use of implementation-specific mechanisms is permitted by the ePAPR. CPUs with this capability
8 are indicated by an implementation-specific value in the *enable-method* property of a CPU node. A
9 client program can release these types of CPUs using implementation-specific means not specified by
10 the ePAPR.

11

12 5.5.4 Timebase Synchronization

13

14 For configurations that use the spin table method of booting secondary cores (i.e. CPU's *enable-*
15 *method* = "spin-table"), the boot program shall enable and synchronize the time base (TBU and TBL)
16 across the boot and secondary CPUs.

17

18 For configurations that use implementation specific methods (see section 5.5.3) to release secondary
19 cores, the methods must provide some means of synchronizing the time base across CPUs. The
20 precise means to accomplish this, which steps are the responsibility of the boot program, and which
21 are the responsibility of the client program is specified by the implementation specific method.

22

23 5.6 Asymmetric Configuration Considerations

24

25 For multiple CPUs in a partitioned or asymmetric (AMP) configuration, the ePAPR boot requirements
26 apply independently to each *domain* or partition. For example, a four-CPU system could be
27 partitioned into three domains: one SMP domain with two CPUs and two UP domains each with one
28 CPU. Each domain could have distinct client image, device tree, boot cpu, etc.

29

6 Device Bindings

This chapter contains requirements, known as *bindings*, for how specific types and classes of devices are represented in the device tree. The *compatible* property of a device node describes the specific binding (or bindings) to which the node complies.

Bindings may be defined as extensions of other each. For example a new bus type could be defined as an extension of the *simple-bus* binding. In this case, the *compatible* property would contain several strings identifying each binding—from the most specific to the most general (see section 2.3.1, *compatible*).

6.1 Binding Guidelines

6.1.1 General Principles

When creating a new device tree representation for a device, a binding should be created that fully describes the required properties and value of the device. This set of properties shall be sufficiently descriptive to provide device drivers with needed attributes of the device.

Some recommended practices include:

1. Define a compatible string using the conventions described in section 2.3.1.
2. Use the standard properties (defined in sections 2.3 and 2.4) as applicable for the new device. This usage typically includes the *reg* and *interrupts* properties at a minimum.
3. Use the conventions specified in section 6 (*Device Bindings*) if the new device fits into one the ePAPR defined device classes.
4. Use the miscellaneous property conventions specified in section 6.1.2, if applicable.
5. If new properties are needed by the binding, the recommended format for property names is: “<company> , <property-name>”, where <company> is an OUI or short unique string like a stock ticker that identifies the creator of the binding.
Example: `ibm,ppc-interrupt-server#s`

1 6.1.2 Miscellaneous Properties

2
3 This section defines a list of helpful properties that might be applicable to many types of devices and
4 device classes. They are defined here to facilitate standardization of names and usage.

5 6.1.2.1 clock-frequency

6
7 Property: *clock-frequency*

8 Value type: *<prop-encoded-array>*

9 Description:

10 Specifies the frequency of a clock in Hz. The value is a *<prop-encoded-array>* in one of two
11 forms:

- 12 1. a 32-bit integer consisting of one *<u32>* specifying the frequency
 - 13 2. a 64-bit integer represented as a *<u64>* specifying the frequency
- 14

15 6.1.2.2 reg-shift

16
17 Property: *reg-shift*

18 Value type: *<u32>*

19 Description:

20 The *reg-shift* property provides a mechanism to represent devices that are identical in most
21 respects except for the number of bytes between registers. The *reg-shift* property specifies in
22 bytes how far the discrete device registers are separated from each other. The individual
23 register location is calculated by using following formula: “registers address” \ll *reg-shift*. If
24 unspecified, the default value is 0.

25
26 For example, in a system where 16540 UART registers are located at addresses 0x0, 0x4, 0x8,
27 0xC, 0x10, 0x14, 0x18, and 0x1C, a *reg-shift* = *<2>* property would be used to specify
28 register locations.

29 6.1.2.3 label

30
31 Property: *label*

32 Value type: *<string>*

33 Description:

34 The *label* property defines a human readable string describing a device. The binding for a
35 given device specifies the exact meaning of the property for that device.
36
37

1 **6.2 Serial devices**

2 **6.2.1 Serial Class Binding**

3

4 The class of serial devices consists of various types of point to point serial line devices. Examples of
5 serial line devices include the 8250 UART, 16550 UART, HDLC device, and BISYNC device. In
6 most cases hardware compatible with the RS-232 standard fit into the serial device class.

7

8 I²C and SPI (Serial Peripheral Interface) devices shall not be represented as serial port devices because
9 they have their own specific representation.

10 6.2.1.1 clock-frequency

11

12 Property: *clock-frequency*

13 Value type: *<u32>*

14 Description:

15 Specifies the frequency in Hertz of the baud rate generator's input clock.

16 Example:

```
17 clock-frequency = <100000000>;
```

18 6.2.1.2 current-speed

19

20 Property: *current-speed*

21 Value type: *<u32>*

22 Description:

23 Specifies the current speed of a serial device in bits per second. A boot program should set
24 this property if it has initialized the serial device.

25 Example:

```
26 current-speed = <115200>; # 115200 baud
```

27

28

6.2.2 National Semiconductor 16450/16550 Compatible UART Requirements

Serial devices compatible to the National Semiconductor 16450/16550 UART (Universal Asynchronous Receiver Transmitter) should be represented in the device tree using following properties.

Properties

Table 6-1 ns16550 properties

| Property Name | Usage | Value Type | Definition |
|--|-------|----------------------|--|
| compatible | R | <stringlist> | Value shall include "ns16550". |
| clock-frequency | R | <u32> | Specifies the frequency (in Hz) of the baud rate generator's input clock |
| current-speed | OR | <u32> | Specifies current serial device speed in bits per second |
| reg | R | <prop-encoded-array> | Specifies the physical address of the registers device within the address space of the parent bus |
| interrupts | OR | <prop-encoded-array> | Specifies the interrupts generated by this device. The value of the <i>interrupts</i> property consists of one or more interrupt specifiers. The format of an interrupt specifier is defined by the binding document describing the node's interrupt parent. |
| reg-shift | O | <u32> | Specifies in bytes how far the discrete device registers are separated from each other. The individual register location is calculated by using following formula: "registers address" << reg-shift. If unspecified, the default value is 0. |
| virtual-reg | SD | <u32> or <u64> | See section 2.3.7. Specifies an effective address that maps to the first physical address specified in the <i>reg</i> property. This property is required if this device node is the system's console. |
| Usage legend: R=Required, O=Optional, OR=Optional but Recommended, SD=See Definition | | | |
| Note: All other standard properties (section 2.3) are allowed but are optional. | | | |

6.3 Network devices

Network devices are packet oriented communication devices. Devices in this class are assumed to implement the data link layer (layer 2) of the seven-layer OSI model and use Media Access Control (MAC) addresses. Examples of network devices include Ethernet, FDDI, 802.11, and Token-Ring.

6.3.1 Network Class Binding

6.3.1.1 address-bits

Property: *address-bits*

Value type: <u32>

Description:

Specifies number of address bits required to address the device described by this node. This property specifies number of bits in MAC address. If unspecified, the default value is 48.

Example:

```
address-bits = <48>;
```

1 6.3.1.2 local-mac-address

2

3 Property: *local-mac-address*4 Value type: *<prop-encoded-array>* encoded as array of hex numbers

5 Description:

6 Specifies MAC address that was assigned to the network device described by the node
7 containing this property.

8 Example:

9 `local-mac-address = [00 00 12 34 56 78] ;`

10 6.3.1.3 mac-address

11

12 Property: *mac-address*13 Value type: *<prop-encoded-array>* encoded as array of hex numbers

14 Description:

15 Specifies the MAC address that was last used by the boot program. This property should be
16 used in cases where the MAC address assigned to the device by the boot program is different
17 from the *local-mac-address* property. This property shall be used only if the value differs
18 from *local-mac-address* property value.

19 Example:

20 `mac-address = [0x01 0x02 0x03 0x04 0x05 0x06] ;`

21 6.3.1.4 max-frame-size

22

23 Property: *max-frame-size*24 Value type: *<u32>*

25 Description:

26 Specifies maximum packet length in bytes that the physical interface can send and receive.

27 Example:

28 `max-frame-size = <1518> ;`

29 6.3.2 Ethernet specific considerations

30

31 Network devices based on the IEEE 802.3 collections of LAN standards (collectively referred to as
32 Ethernet) may be represented in the device tree using following properties, in addition to properties
33 specified of the *network* device class.

34

35 The properties listed in this section augment the properties listed in the *network* device class.36

6.3.2.1 max-speed

Property: *max-speed*

Value type: *<u32>*

Description:

Specifies maximum speed (specified in megabits per second) supported the device.

Example:

```
max-speed = <1000>;
```

6.3.2.2 phy-connection-type

Property: *phy-connection-type*

Value type: *<string>*

Description:

Specifies interface type between the Ethernet device and a physical layer (PHY) device. The value of this property is specific to the implementation.

Recommended values are shown in the following table.

| Connection type | Value |
|---|--------------|
| Media Independent Interface | "mii" |
| Reduced Media Independent Interface | "rmii" |
| Gigabit Media Independent Interface | "gmii" |
| Reduced Gigabit Media Independent Interface | "rgmii" |
| rgmii with internal delay | "rgmii-id" |
| rgmii with internal delay on TX only | "rgmii-txid" |
| rgmii with internal delay on RX only | "rgmii-rxid" |
| Ten Bit Interface | "tbi" |
| Reduced Ten Bit Interface | "rtbi" |
| Serial Media Independent Interface | "smii" |

Example:

```
phy-connection-type = "mii";
```

6.3.2.3 phy-handle

Property: *phy-handle*

Value type: *<phandle>*

Description:

Specifies a reference to a node representing a physical layer (PHY) device connected to this Ethernet device. This property is required in case where the Ethernet device is connected a physical layer device.

Example:

```
phy-handle = <&PHY0>;
```

6.4 open PIC Interrupt Controllers

This section specifies the requirements for representing open PIC compatible interrupt controllers. An open PIC interrupt controller implements the open PIC architecture (developed jointly by AMD and Cyrix) and specified in *The Open Programmable Interrupt Controller (PIC) Register Interface Specification Revision 1.2* [18].

Interrupt specifiers in an open PIC interrupt domain are encoded with two cells. The first cell defines the interrupt number. The second cell defines the sense and level information.

Sense and level information shall be encoded as follows in interrupt specifiers:

- 0 = low to high edge sensitive type enabled
- 1 = active low level sensitive type enabled
- 2 = active high level sensitive type enabled
- 3 = high to low edge sensitive type enabled

Properties

Table 6-2 Open-pic properties

| Property Name | Usage | Value Type | Definition |
|--|-------|------------------------------|---|
| compatible | R | <string> | Value shall include "open-pic". |
| reg | R | <prop- encoded- array> | Specifies the physical address of the registers device within the address space of the parent bus |
| interrupt-controller | R | <empty> | Specifies that this node is an interrupt controller |
| #interrupt-cells | R | <u32> | Shall be 2. |
| #address-cells | R | <u32> | Shall be 0. |
| Usage legend: R=Required, O=Optional, OR=Optional but Recommended, SD=See Definition | | | |
| Note: All other standard properties (section 2.3) are allowed but are optional. | | | |

6.5 simple-bus

System-on-a-chip processors may have an internal I/O bus that cannot be probed for devices. The devices on the bus can be accessed directly without additional configuration required. This type of bus is represented as a node with a compatible value of "simple-bus".

Properties

Table 6-3 Simple-bus properties

| Property Name | Usage | Value Type | Definition |
|--|-------|------------------------------|--|
| compatible | R | <string> | Value shall include <code>simple-bus</code> . |
| ranges | R | <prop- encoded- array> | This property represents the mapping between parent address to child address spaces (see section 2.3.8, <i>ranges</i>). |
| Usage legend: R=Required, O=Optional, OR=Optional but Recommended, SD=See Definition | | | |
| Note: All other standard properties (section 2.3) are allowed but are optional. | | | |

7 Virtualization

7.1 Overview

The power.org Embedded Power Architecture Platform Requirements (ePAPR) defines virtualization standards including:

- Hypercall ABI
- Hypercall services
- Virtualization extensions to the device tree, so that guest operating systems are aware of the resources and services offered by a hypervisor

7.2 Hypercall Application Binary Interface (ABI)

An explicit invocation of the hypervisor by a guest is called a hypercall or hcall. This is performed by executing an instruction that causes an exception, in much the same way as a Unix system call is performed. One argument is a token that designates the actual function to perform. The remaining arguments and their interpretation are specific to the function of the hcall.

The hcall function depends on a modified system call (LEVEL=1) instruction which traps directly to hypervisor mode in the processor.

Summary

- The hypercall number shall be contained in r11.
- Input parameters shall be contained in r3 through r10, inclusive.
- Hypercalls shall return a success code and place this value in r3.
- Further output parameters shall be contained in r4 through r11, inclusive.
- If more data must be transferred in either direction in a single hypercall, that data must be placed into memory, and that must be specified by the hypercall API (the ABI does not define this behavior).

Table 7-1. Register Volatility

| Register | Description |
|---------------------|--|
| r0 | Volatile |
| r1–r2 | Nonvolatile |
| r3 | Volatile parameter and return value for status |
| r4–r10 | Volatile input and output value |
| r11 | Volatile hypercall Token and output value |
| r12 | Volatile |
| r13–r31 | Nonvolatile |
| LR | Nonvolatile |
| CTR | Volatile |
| XER | Volatile |
| CR2–CR4 | Nonvolatile |
| Remaining CR fields | Volatile |
| Other Registers | Nonvolatile |

Contents of registers that are considered "nonvolatile" shall be preserved across hypercalls.

1

2 **7.3 ePAPR Hypercall Token Definition**3 The ePAPR hcall ABI specifies that an hcall token identifying the hcall be placed in r11. An hcall
4 token is 32-bits and is defined as follows:

5

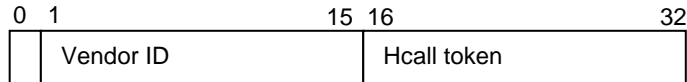

6

7 Bit 0 (msb) is reserved and must be zero.

8

The vendor ID encoding is a 15-bit value defined as specified in Table 7-2:

9

10

Table 7-2, Vendor ID encoding

| Vendor ID | Vendor Name |
|-----------|---------------------------------------|
| 0 | reserved for private, local use |
| 1 | ePAPR (hcall is defined by the ePAPR) |
| 2 | Freescale Semiconductor |
| 3 | International Business Machines |
| 4 | Green Hills Software |
| 5 | Enea |
| 6 | Wind River Systems |
| 7 | Applied Micro Circuits |
| 42 | KVM (Kernel-based Virtual Machine) |

11

12

The ePAPR hcall tokens values are encoded as specified in Table 7-3. ePAPR Hypercall Token
13 Definition.

14

15

Table 7-3. ePAPR Hypercall Token Definition

| Hypercall Token Symbolic Name | Value |
|-------------------------------|-------|
| EV_BYTE_CHANNEL_SEND | 1 |
| EV_BYTE_CHANNEL_RECEIVE | 2 |
| EV_BYTE_CHANNEL_POLL | 3 |
| EV_INT_SET_CONFIG | 4 |
| EV_INT_GET_CONFIG | 5 |
| EV_INT_SET_MASK | 6 |
| EV_INT_GET_MASK | 7 |
| EV_INT_IACK | 9 |
| EV_INT_EOI | 10 |

| Hypercall Token Symbolic Name | Value |
|-------------------------------|-------|
| EV_INT_SEND_IPI | 11 |
| EV_INT_SET_TASK_PRIORITY | 12 |
| EV_INT_GET_TASK_PRIORITY | 13 |
| EV_DOORBELL_SEND | 14 |
| EV_MSGSND | 15 |
| EV_IDLE | 16 |

1 7.4 Hypercall Return Codes

2 Hypercalls return a status value in r3 encoded as follows:

3

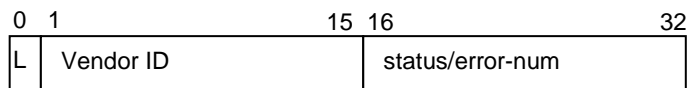

4

5 Vendor specific errors are encoded by setting the vendor ID (see table 1-1).

6

Local/private errors that are not vendor specific can be encoded by setting the L bit.

7

The following tables defines the return codes that may be returned from hypercalls. A return code of zero indicates that the hypercall succeeded.

8

9

10

Table 7-4. ePAPR hcall return codes

| Symbolic Name | Value | Meaning |
|--------------------|-------|--|
| | 0 | Success-- the operation completed successfully |
| EV_EPERM | 1 | Operation not permitted |
| EV_ENOENT | 2 | Entry Not Found |
| EV_EIO | 3 | I/O error occurred |
| EV_EAGAIN | 4 | The operation had insufficient resources to complete and should be retried |
| EV_ENOMEM | 5 | There was insufficient memory to complete the operation |
| EV_EFAULT | 6 | Bad guest address |
| EV_ENODEV | 7 | No such device |
| EV_EINVAL | 8 | An argument supplied to the hcall was out of range or invalid |
| EV_INTERNAL | 9 | An internal error occurred |
| EV_CONFIG | 10 | A configuration error was detected |
| EV_INVALID_STATE | 11 | The object is in an invalid state |
| EV_UNIMPLEMENTED | 12 | Unimplemented hypercall |
| EV_BUFFER_OVERFLOW | 13 | Caller-supplied buffer too small |

1

2 **7.5 Hypervisor Node**3 Guest operating system can determine the virtualization resources available to them by looking at the
4 **/hypervisor** node that will be present in the device tree passed to the guest operating system.

5

6 The name of the hypervisor node shall be “hypervisor” and it must be located at the root of the guest
7 device tree.

8

9 The hypervisor node support the following properties:

10

11

Table 7-5. ePAPR hypervisor node

| Property Name | Usage | Value Type | Definition |
|--|-------|----------------------|--|
| compatible | R | <string> | Must contain "epapr,hypervisor-<version#>" Where version# indicates the version of the ePAPR virtualization extensions that the hypervisor is compatible with. |
| hcall-instructions | R | <prop-encoded-array> | Consists of up to 4 cells that specify a sequence of Power ISA instructions used in making a hypercall. Each cell contains a Power ISA opcode. Example: hcall-instructions = <0x44000022>; // sc level=1 |
| guest-id | R | <u32> | A hypervisor provided guest identification number that is guaranteed to be unique across all partitions. |
| guest-name | R | <string> | A human readable string that describes the guest |
| has-idle | SD | <none> | If present, the hypervisor supports the EV_IDLE hcall |
| has-msgsnd-hcall | SD | <none> | If present, the hypervisor supports the EV_MSGSND hcall |
| Usage legend: R=Required, O=Optional, OR=Optional but Recommended, SD=See Definition | | | |

12

9

10 **7.6 ePAPR Virtual Interrupt Controller Services**

11 In a virtualized implementation of the Power Architecture, interrupt controller services may be
 12 provided by a virtual interrupt controller accessed via a hypercall interface. The ePAPR virtual
 13 interrupt controller provides interrupt controller services for external interrupts.

14

15 External interrupts received by a partition can come from two sources:

- 16 • Hardware interrupts - hardware interrupts come from external interrupt lines or on-chip I/O
 17 devices
- 18 • Virtual interrupts - virtual interrupts are generated by the hypervisor as part of some
 19 hypervisor service or hypervisor-created virtual device.

20

21 Both types of interrupts are processed using the same programming model and same set of hcalls.
 22 Each interrupt source in a partition has a partition-wide unique interrupt source number. Interrupt
 23 number 0 is reserved, and indicates a spurious interrupt (see the EV_INT_IACK hcall).

24

25

Table 7-6. interrupt controller hcalls

| Hypercall | Description |
|--------------------------|---|
| EV_INT_SET_CONFIG | Configures an interrupt |
| EV_INT_GET_CONFIG | Returns the configuration of an interrupt |
| EV_INT_SET_MASK | Sets the mask for an interrupt |
| EV_INT_GET_MASK | Returns the mask for an interrupt |
| EV_INT_IACK | Acknowledges an interrupt |
| EV_INT_EOI | Signals the end of processing for an interrupt |
| EV_INT_SEND_IPI | Sends an interprocessor interrupt to other CPUs/threads |
| EV_INT_SET_TASK_PRIORITY | Sets the current task priority for the specified interrupt controller |
| EV_INT_GET_TASK_PRIORITY | Gets the current task priority for the specified interrupt controller |

26 **7.6.1 Virtual Interrupt Controller Device Tree Representation**

27 7.6.1.1 Interrupt Controller Node

28 The ePAPR virtual interrupt controller is represented as a node in guest device trees with the
 29 properties as described in Table 7-11:

30

31

Table 7-7. ePAPR virtual interrupt controller

| Property Name | Usage | Value Type | Definition |
|------------------|-------|------------|--|
| compatible | R | <string> | Must contain "epapr,hv-pic". |
| hv-handle | O | <u32> | Specifies a handle to the interrupt controller. This handle may be used in hcalls that require an interrupt controller handle. |
| #interrupt-cells | R | <u32> | Must be 2 |

| | | | |
|--|----|--------|---|
| #address-cells | R | <u32> | Must be 0 |
| interrupt-controller | R | <none> | Property must be present to indicate that this node is an interrupt controller |
| priority-count | R | <u32> | Defines the number of priorities supported by the virtual interrupt controller. The lowest priority (least-favored) is 0. |
| has-task-priority | SD | <none> | If present indicates that the virtual interrupt controller supports setting the current task priority. See the EV_SET_TASK_PRIORITY hcall. |
| has-external-proxy | SD | <none> | If present, indicates that the hardware platform and virtual interrupt controller support the external proxy feature of the Power architecture. |
| no-priority | SD | <none> | If present indicates that the virtual interrupt controller does not implement the interrupt priority mechanism. |
| Usage legend: R=Required, O=Optional, OR=Optional but Recommended, SD=See Definition | | | |

1

2 7.6.1.2 Interrupt Specifiers

3 The *interrupts* property of interrupt children of the "epapr,hv-pic" node consists of two cells encoded
4 as follows:

5 <*interrupt-src-number flags*>

6 Where:

- 7 • *interrupt-src-number* specifies the interrupt source number that may be used in the
8 hcalls to configure and manage the interrupt source
- 9 • *flags* describes the level-sense encoding of the interrupt, encoded as:

10

11

Table 7-8, epapr,hv-pic interrupt specifier flags encoding

| Bits | Description |
|------|---|
| 31 | Polarity 0 Polarity is active-low or negative edge triggered. 1 Polarity is active-high or positive edge-triggered. |
| 30 | Sense 0 The interrupt is edge sensitive 1 The interrupt is level sensitive |

12

1 7.6.1.3 IPI Representation

2 Interrupt specifiers for IPI interrupt send via the EV_INT_SEND_IPI hcall are represented in a node
3 in a guest device tree as specified in *Table 7-13. ePAPR IPI node properties.*

4

5

Table 7-9. ePAPR IPI node properties

| Property Name | Usage | Value Type | Definition |
|--|-------|------------------------------|--|
| compatible | R | <string> | Must contain "epapr,hv-pic-ipi". |
| interrupts | R | <prop- encoded- array> | An array of interrupt specifiers each corresponding to the IPI channels supported by the EV_INT_SEND_IPI hcall. The interrupt specifiers are encoded as: <channel-0 channel-1 ... channel-n> The number of interrupt specifiers implies the number of IPI channels supported by an implementation. |
| interrupt-parent | O | <phandle> | Points to the interrupt parent. The interrupt specifiers of this node must be in the interrupt domain whose root is the corresponding "epapr,hv-pic" interrupt controller node. |
| Usage legend: R=Required, O=Optional, OR=Optional but Recommended, SD=See Definition | | | |

6

7 7.6.2 ePAPR Interrupt Controller Hypercalls

8 7.6.2.1 EV_INT_SET_CONFIG

9 **Hypercall:** EV_INT_SET_CONFIG

10

11

Description: Configures the priority, destination CPU, and level/sense for an interrupt source

12

Arguments:

13

| | | |
|-----|-------------|--|
| r11 | hcall-token | EV_INT_SET_CONFIG |
| r3 | interrupt | Interrupt source number (from the interrupt specifier) |
| r4 | config | Specifies the configuration of the interrupt source. The config value is encoded as described in <i>Table 7-12, epapr,hv-pic interrupt specifier flags encoding.</i> |
| r5 | priority | Priority. Specifies the interrupt priority. The allowable range of priorities (lowest to highest) is described by the "priority-count" property on the "epapr,hv-pic" node. A priority value of 0 inhibits signaling of this interrupt. |
| r6 | destination | Destination CPU. A number that identifies which CPU/thread receives the interrupt. This value matches the device tree "reg" property corresponding to the CPU/thread. |

14 **Return values:**

| | | |
|----|--------|--|
| r3 | Status | Status of the hypercall 0 : the operation completed successfully EV_EINVAL : a parameter was out of range or invalid |
|----|--------|--|

15

1 7.6.2.2 EV_INT_GET_CONFIG

2 **Hypercall:** EV_INT_GET_CONFIG3 **Description:** Returns the configuration of the specified interrupt4 **Arguments:**

| | | |
|-----|-------------|--|
| r11 | hcall-token | EV_INT_GET_CONFIG |
| r3 | Interrupt | Interrupt source number (from the interrupt specifier) |

5 **Return values:**

| | | |
|----|-------------|--|
| r3 | Status | Status of the hypercall 0: the operation completed successfully EV_EINVAL : the interrupt number was invalid |
| r4 | config | Interrupt configuration. See <i>Table 7-12, epapr,hv-pic interrupt specifier flags encoding</i> for a description of the bit encoding of this value. |
| r5 | priority | Priority. Specifies the interrupt priority. The allowable range of priorities (lowest to highest) is described by the "priority-count" property on the "epapr,hv-pic" node. A priority value of 0 inhibits signaling of this interrupt. |
| r6 | destination | Destination CPU. A number that identifies which CPU/thread receives the interrupt. This value matches the device tree "reg" property corresponding to the CPU/thread. |

6

7 7.6.2.3 EV_INT_SET_MASK

8 **Hypercall:** EV_INT_SET_MASK

9

10 **Description:** Sets the mask for the specified interrupt source11 **Arguments:**

| | | |
|-----|-------------|--|
| r11 | hcall-token | EV_INT_SET_MASK |
| r3 | interrupt | Interrupt source number (from the interrupt specifier) |
| r4 | mask | Specifies whether the interrupt source is masked Zero: This interrupt source is enabled nonzero: This interrupt source is disabled |

12 **Return values:**

| | | |
|----|--------|---|
| r3 | status | Status of the hypercall 0 : the operation completed successfully EV_EINVAL : the interrupt number was invalid |
|----|--------|---|

13

1 7.6.2.4 EV_INT_GET_MASK

2 **Hypercall:** EV_INT_GET_MASK3 **Description:** Returns the mask for the specified interrupt source4 **Arguments:**

| | | |
|-----|-------------|--|
| r11 | hcall-token | EV_INT_GET_MASK |
| r3 | interrupt | Interrupt source number (from the interrupt specifier) |

5 **Return values:**

| | | |
|----|--------|--|
| r3 | status | Status of the hypercall 0 : the operation completed successfully EV_EINVAL : the interrupt number was invalid |
| r4 | mask | Specifies whether the interrupt source is masked Zero: This interrupt source is enabled nonzero: This interrupt source is disabled |

6

7 7.6.2.5 EV_INT_IACK

8 **Hypercall:** EV_INT_IACK

9 **Description:** Acknowledges an interrupt. EV_INT_IACK returns the interrupt source number
10 corresponding to the highest priority pending interrupt. EV_INT_IACK also has the side effect of
11 negating the corresponding int output signal from the interrupt controller.

12 **Arguments:**

| | | |
|-----|-------------|---|
| r11 | hcall-token | EV_INT_IACK |
| r3 | handle | If zero, returns the next interrupt source number to be handled irrespective of the hierarchy or cascading of interrupt controllers. If, non-zero, specifies a handle to the interrupt controller that is the target of the acknowledge. The typical use for a non-zero handle value would be for processing interrupts with a cascaded interrupt controller, where the external proxy mechanism returned the root level interrupt source number and the guest operating system manages the cascaded controller. |

13 **Return values:**

| | | |
|----|-------------|--|
| r3 | status | Status of the hypercall 0 success EV_INVALID_STATE— the virtual interrupt controller supports external proxy mode and the invocation of FH_VMPIC_IACK call is not supported |
| r4 | int-src-num | The interrupt source number corresponding to the highest priority pending interrupt. Invoking EV_INT_IACK when no interrupt is pending returns spurious interrupt source number 0. |

14

15

1 7.6.2.6 EV_INT_EOI

2 **Hypercall:** EV_INT_EOI

3

4 **Description:** Signals the end of processing for the specified interrupt, which must be the highest
5 priority interrupt currently in service.

6

7 An "in service" interrupt is one that has been acknowledged-- either explicitly via EV_INT_IACK or
8 by hardware that supports Power Architecture Category: External Proxy.9 **Arguments:**

| | | |
|-----|-------------|--|
| r11 | hcall-token | FH_VMPIC_EOI |
| r3 | interrupt | Interrupt source number (from the interrupt specifier) |

10 **Return values:**

| | | |
|----|--------|--|
| r3 | status | Status of the hypercall 0 the operation completed successfully EV_INTERNAL—an error occurred |
|----|--------|--|

11 Note: It is the responsibility of guest software to ensure that the interrupt source specified in this hcall
12 is the highest priority interrupt in service.

13

1 7.6.2.7 EV_INT_SEND_IPI

2 **Hypercall:** EV_INT_SEND_IPI

3

4 **Description:** An intra-partition interrupt mechanism that causes an external interrupt at the
5 destination virtual CPU(s).6 **Arguments:**

| | | |
|-----|-------------|---|
| r11 | hcall-token | EV_INT_SEND_IPI |
| r3 | ipi channel | A number that specifies which IPI channel to use. See the "epapr,hv-pic-ipi" node for information on the number of available channels. |
| r4 | destination | Destination CPU. A number that identifies which CPU/thread receives the interrupt. This value matches the device tree "reg" property corresponding to the CPU/thread. A value of 0xffffffff means that an interrupt should be broadcast to all CPUs/threads. |

7 **Return values:**

| | | |
|----|--------|--|
| r3 | status | Status of the hypercall 0 the operation completed successfully EV_INTERNAL—an error occurred |
|----|--------|--|

8

Programming Note

ePAPR interrupt controller hypercalls are guaranteed to be atomic and to be performed in program order with respect to all processors. For storage access ordering, ePAPR interrupt controller hypercalls are treated as data accesses with respect to memory barriers.

ePAPR interrupt controller hypercalls can be ordered with respect to storage accesses by the "sync" and "mbar 0" instructions.

9

10

1 7.6.2.8 EV_INT_SET_TASK_PRIORITY

2 **Hypercall:** EV_INT_SET_TASK_PRIORITY

3

4 **Description:** Sets the current task priority for the specified interrupt controller. The current task
 5 priority is a per-virtual-cpu and per-interrupt controller attribute. Setting the task priority indicates
 6 the relative importance of the task running on the specified cpu.

7

8 The default task priority is set to the maximum priority (as specified by the "priority-count" property
 9 on the interrupt controller node). This means that the EV_INT_SET_TASK_PRIORITY hcall must
 10 be called for each cpu to enable interrupts.

11

12 The default task priority is 0.

13 **Arguments:**

| | | |
|-----|---------------|---|
| r11 | hcall-token | EV_INT_SET_TASK_PRIORITY |
| r3 | handle | Handle to the interrupt controller for which the priority is to be configured. |
| r4 | task priority | <p>Indicates the threshold that individual interrupt priorities must exceed for the interrupt to be serviced.</p> <p>Valid values range from 0 to the value described by the described by the <i>priority-count</i> property on the "epapr,hv-pic" node.</p> <p>A priority value of 0 means that all interrupts except those whose priority is 0 can be serviced.</p> <p>The <i>priority-count</i> property specifies the number of priorities supported by an interrupt controller. A priority value equal to (priority-count - 1) means that no interrupts are signaled to the specified CPU.</p> |

14 **Return values:**

| | | |
|----|--------|---|
| r3 | status | <p>Status of the hypercall</p> <p>0 the operation completed successfully</p> <p>EV_INTERNAL—an error occurred</p> |
|----|--------|---|

15

16

1 7.6.2.9 EV_INT_GET_TASK_PRIORITY

2 **Hypercall:** EV_INT_GET_TASK_PRIORITY

3

4 **Description:** Gets the current task priority for the specified interrupt controller.5 **Arguments:**

| | | |
|-----|-------------|---|
| r11 | hcall-token | EV_INT_SET_TASK_PRIORITY |
| r3 | handle | Handle to the interrupt controller for which the priority is being queried. |
| | | |

6 **Return values:**

| | | |
|----|---------------|--|
| r3 | status | Status of the hypercall 0 the operation completed successfully EV_INTERNAL—an error occurred |
| r4 | task priority | Indicates the threshold that individual interrupt priorities must exceed for the interrupt to be serviced. |

7

8

1 **7.7 Byte-channel Services**

2 **7.7.1 Overview**

3 A byte-channel is a hypercall-based, interrupt-driven character-based I/O channel (similar to a UART).
 4 Hypercalls are available to send, receive, and poll a channel.

5

6 **Table 7-10. hcalls for Byte-Channel Services**

| Hypercall | Description |
|-------------------------|---|
| EV_BYTE_CHANNEL_SEND | Sends data to a byte-channel. |
| EV_BYTE_CHANNEL_RECEIVE | Receives bytes of data from a byte-channel. |
| EV_BYTE_CHANNEL_POLL | Returns the status of the byte-channel send and receive buffers |

7

8

1 7.7.2 Interrupts and Guest Device Tree Representation

2 Byte-channels are specified in the guest device tree as follows:

3 **Table 7-11. Guest Device Tree**

| Property Name | Usage | Value Type | Definition |
|--|-------|-------------------------|--|
| compatible | R | <stringlist> | Must be "epapr,hv-byte-channel" |
| hv-handle | R | <u32> | Specifies the handle to the byte-channel. This value must be used by guest software for all byte-channel related hypercalls. |
| interrupts | R | <prop- encoded-array | <p>Must consist of one or two interrupt specifiers encoded as follows:</p> <p style="text-align: center;"><i><rx-interrupt-specifier [tx-interrupt-specifier]></i></p> <p>If only one interrupt specifier is present, then the implementation does not support TX interrupts.</p> <p>The virtual device shall generate a receive interrupt (RX) after an increase in the number of bytes available in the byte-channel's receive buffer.</p> <p>If implemented, the virtual device shall generate a transmit interrupt (TX) after an increase in the space available in the byte-channel's transmit buffer.</p> <p>Both TX and RX interrupts shall be edge-triggered.</p> |
| Usage legend: R=Required, O=Optional, OR=Optional but Recommended, SD=See Definition | | | |

4

5

1 7.7.3 Byte-channel Hypercalls

2 The byte-channel hypercalls are nonblocking and synchronous. All hypercalls perform the requested
3 task and return. There are no asynchronous side effects. If the request could not be completed (e.g. no
4 space, no data) the return code of the hypercall indicates the reason the call did not complete.

5 7.7.3.1 EV_BYTE_CHANNEL_SEND

6 **Hypercall:** EV_BYTE_CHANNEL_SEND

7
8 **Description:** Description: Sends data to a byte-channel. The maximum number of bytes that can be
9 sent is 16.

10 **Arguments:**

| | | |
|-------------|-------------|---|
| r11 | hcall-token | EV_BYTE_CHANNEL_SEND |
| r3 | handle | Byte-channel handle |
| r4 | count | has count of bytes available in r5, r6, r7, and r8 |
| r5,r6,r7,r8 | byte string | The byte string starts in register r5 and proceeds toward the low order byte in register r8 for the number of characters specified in r4. The contents of all other byte locations of registers r5-r8 are undefined. Each register holds at most 4 bytes, which means on 64-bit CPUs only the low order 4 bytes of the registers are defined. |

11 **Return values:**

| | | |
|----|--------|---|
| r3 | status | Status of the hypercall 0 : the operation completed successfully EV_EINVAL: Invalid parameter EV_EAGAIN: The byte-channel buffer did not have sufficient space and no characters were sent. The operation should be retried at a later time. |
| r4 | count | Count of characters sent. |

12 7.7.3.2 EV_BYTE_CHANNEL_RECEIVE

13 **Hypercall:** EV_BYTE_CHANNEL_RECEIVE

14
15 **Description:** Receives bytes of data from a byte-channel. The maximum number of bytes received is
16 16.

17 **Arguments:**

| | | |
|-----|------------------------|---|
| r11 | hcall-token | EV_BYTE_CHANNEL_RECEIVE |
| r3 | handle | Byte-channel handle |
| r4 | max receive byte count | Specifies the maximum number of characters to receive. This value can be no larger than 16. |

1 **Return values:**

| | | |
|-------------|------------------|---|
| r3 | status | Status of the hypercall 0 : the operation completed successfully EV_EINVAL : a parameter was invalid |
| r4 | count | Count of characters available in r5, r6, r7 and r8 A count of zero indicates no characters are available. |
| r5,r6,r7,r8 | character string | The byte string starts in register r5 and proceeds toward the low order byte in register r8 for the number of characters specified in r4. The contents of all other byte locations of registers r5-r8 are undefined. Each register holds at most 4 bytes, which means on 64-bit CPUs only the low order 4 bytes of the registers are defined. |

2

3 **7.7.3.3 EV_BYTE_CHANNEL_POLL**4 **Hypercall:** EV_BYTE_CHANNEL_POLL

5

6 **Description:** returns the status of the byte-channel send and receive buffers7 **Arguments:**

| | | |
|-----|-------------|----------------------|
| r11 | hcall-token | EV_BYTE_CHANNEL_POLL |
| r3 | handle | Byte-channel handle |

8 **Return values:**

| | | |
|----|----------|---|
| r3 | status | Status of the hypercall 0 : the operation completed successfully EV_EINVAL : handle was invalid |
| r4 | rx count | Count of bytes available in the byte-channel's receive buffer. |
| r5 | tx count | Count of space available in the byte-channel's transmit buffer. |

9

10

1 **7.8 Inter-partition Doorbells**

2 **7.8.1 Overview**

3 A doorbell is an inter-partition signaling mechanism. A doorbell allows one partition to cause an
4 interrupt in one (or possibly more) target partitions. The doorbell results in an external interrupt in the
5 destination partition (i.e. the interrupt is gated by MSR[EE] and the exception handler specified in
6 IVOR4 executes).

7
8 Note, doorbell interrupts may be coalesced-- if multiple senders issue a doorbell to the same receive
9 endpoint, the receiver may see only one interrupt. If a sender issues multiple doorbells to a receiver
10 that has interrupts disabled the receiver may only see one interrupt.

11 A partition is aware of the doorbells available to it through its guest device tree which contains a node
12 for each doorbell endpoint.

13 **7.8.2 Doorbell Send Endpoints**

14 Doorbell send endpoints are represented in a guest device tree with the following properties:

15 **Table 7-12. Doorbell Send Endpoints**

| Property Name | Usage | Value Type | Definition |
|--|-------|--------------|--|
| compatible | R | <stringlist> | Must include "epapr,hv-doorbell-send-handle" |
| hv-handle | R | <u32> | Specifies the handle to the doorbell. This value must be used by guest software for doorbell related hypercalls. |
| Usage legend: R=Required, O=Optional, OR=Optional but Recommended, SD=See Definition | | | |

16 **7.8.3 Doorbell Receive Endpoints**

17 Doorbell receive endpoints are represented in a guest device tree with the following properties:

18
19 **Table 7-13. Doorbell Receive Endpoints**

| Property Name | Usage | Value Type | Definition |
|--|-------|--------------------------|--|
| compatible | R | <stringlist> | Must be "epapr,hv-doorbell-receive-handle" |
| interrupts | R | <prop- encoded-array> | Must consist of one interrupt specifier. |
| Usage legend: R=Required, O=Optional, OR=Optional but Recommended, SD=See Definition | | | |

20

21

1

2 **7.8.4 Doorbell Hypercall**3 **Hypercall:** EV_DOORBELL_SEND

4

5 **Description:** Sends a doorbell signal to a partition. This causes an external interrupt in the destination
6 partition.7 **Arguments:**

| | | |
|-----|-------------|---|
| r11 | hcall-token | EV_DOORBELL_SEND |
| r3 | handle | Specifies the doorbell handle of the partition to signal. This handle comes from the device tree. |

8 **Return values:**

| | | |
|----|--------|---|
| r3 | status | Status of the hypercall 0 : the operation completed successfully EV_EINVAL : handle was invalid EV_CONFIG: there was a configuration error with the doorbell |
|----|--------|---|

9 **7.9 msgsnd**10 **7.9.1 EV_MSGSND**11 **Hypercall:** EV_MSGSND

12

13 **Description:** Causes a "Processor Doorbell Exception" at the destination CPU(s).14 When a thread takes a Processor Doorbell Interrupt, the pending Processor Doorbell Exception is
15 cleared, regardless of how many messages caused the Processor Doorbell Exception.16 A message sent by the msgsnd hypercall is ordered according to the requirements that would be
17 imposed by the architecture if the message were sent using the "msgsnd" instruction instead.

18 Specifically, the sending of the message is treated as a store with respect to memory barriers.

19

20 **Arguments:**

| | | |
|-----|-------------|--|
| r11 | hcall-token | EV_MSGSND |
| r3 | pir | Specifies the PIR of the destination CPU |
| r4 | broadcast | A value of 0 specifies that the doorbell is not to be broadcast. A value of 1 specifies that the doorbell is to be broadcast to all cpus/threads in the partition regardless of the value of the PIR register and the value of the PIR argument. |

21

22 **Return values:**

| | | |
|----|--------|---|
| r3 | status | Status of the hypercall 0 : the operation completed successfully |
|----|--------|---|

23

 1 **7.10 Idle**
2 **EV_IDLE**3 **Hypercall:** EV_IDLE

4

5 **Description:** The EV_IDLE hcall provides a mechanism for a guest operating system to tell the
 6 hypervisor that it is idle. It is recommended that this mechanism be used by guests instead of the
 7 'wait' instruction.

8 **Arguments:**

| | | |
|-----|-------------|---------|
| r11 | hcall-token | EV_IDLE |
|-----|-------------|---------|

9 **Return values:**

| | | |
|----|--------|--|
| r3 | status | Status of the hypercall 0 : the operation completed successfully EV_UNIMPLEMENTED : the hypervisor does not implement the EV_IDLE hcall |
|----|--------|--|

10

11

12

8 Flat Device Tree Physical Structure

An ePAPR boot program communicates the entire device tree to the client program as a single, linear, pointerless data structure known as the *flattened device tree* or *device tree blob*.

This data structure consists of a small header (see 8.2), followed by three variable sized sections: the memory reservation block (see 8.3), the structure block (see 8.4) and the strings block (see 8.5). These should be present in the flattened device tree in that order.

Thus, the device tree structure as a whole, when loaded into memory at address, will resemble the diagram in Figure 8-1 (lower addresses are at the top of the diagram).

Figure 8-1 Device Tree Structure

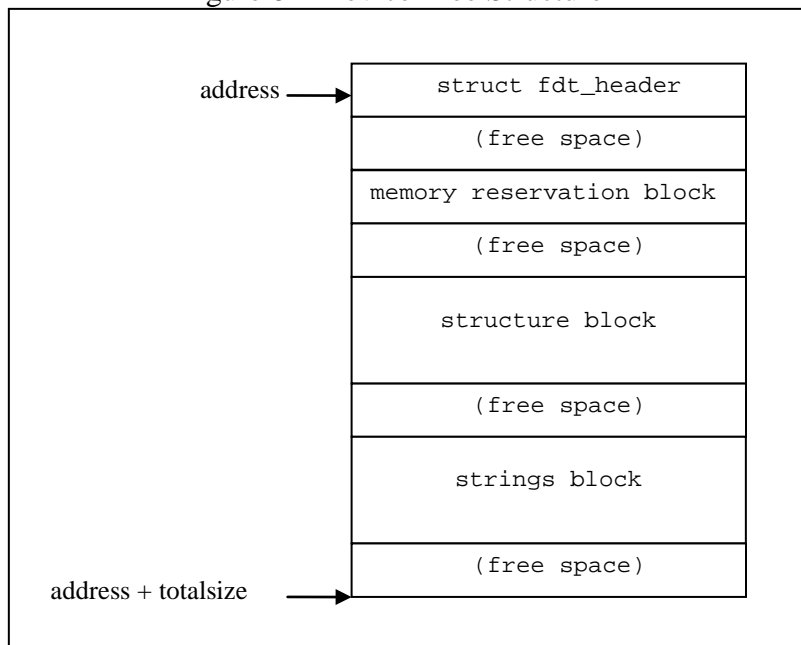

The (free space) sections may not be present, though in some cases they might be required to satisfy the alignment constraints of the individual blocks (see 8.6).

8.1 Versioning

Several versions of the flattened device tree structure have been defined since the original definition of the format. Fields in the header give the version, so that the client program can determine if the device tree is encoded in a compatible format.

This document describes only version 17 of the format. ePAPR-compliant boot programs shall provide a device tree of version 17 or later, and should provide a device tree of a version that is backwards compatible with version 16. ePAPR-compliant client programs shall accept device trees of any version backwards compatible with version 17 and may accept other versions as well.

1
2 **Note:** The version is with respect to the binary structure of the device tree, not its content.
3

4 **8.2 Header**

5
6 The layout of the header for the device tree is defined by the following C structure. All the header
7 fields are 32-bit integers, stored in big-endian format.
8

```
9         struct fdt_header {  
10             uint32_t magic;  
11             uint32_t totalsize;  
12             uint32_t off_dt_struct;  
13             uint32_t off_dt_strings;  
14             uint32_t off_mem_rsvmap;  
15             uint32_t version;  
16             uint32_t last_comp_version;  
17             uint32_t boot_cpuid_phys;  
18             uint32_t size_dt_strings;  
19             uint32_t size_dt_struct;  
20         };  
21
```

- 22 • `magic`

23
24 This field shall contain the value 0xd00dfeed (big-endian).
25

- 26 • `totalsize`

27
28 This field shall contain the total size of the device tree data structure. This size shall
29 encompass all sections of the structure: the header, the memory reservation block, structure
30 block and strings block, as well as any free space gaps between the blocks or after the final
31 block.
32

- 33 • `off_dt_struct`

34
35 This field shall contain the offset in bytes of the structure block (see 8.4) from the beginning
36 of the header.
37

- 38 • `off_dt_strings`

39
40 This field shall contain the offset in bytes of the strings block (see 8.5) from the beginning of
41 the header.
42

- 43 • `off_mem_rsvmap`

44
45 This field shall contain the offset in bytes of the memory reservation block (see 8.3) from the
46 beginning of the header.

1
2
3
4
5
6
7
8
9
10
11
12
13
14
15
16
17
18
19
20
21
22
23
24
25
26
27
28
29
30
31

- `version`

This field shall contain the version of the device tree data structure. The version is 17 if using the structure as defined in this document. An ePAPR boot program may provide the device tree of a later version, in which case this field shall contain the version number defined in whichever later document gives the details of that version.

- `last_comp_version`

This field shall contain the lowest version of the device tree data structure with which the version used is backwards compatible. So, for the structure as defined in this document (version 17), this field shall contain 16 because version 17 is backwards compatible with version 16, but not earlier versions. As per 8.1, an ePAPR boot program should provide a device tree in a format which is backwards compatible with version 16, and thus this field shall always contain 16.

- `boot_cpuid_phys`

This field shall contain the physical ID of the system's boot CPU. It shall be identical to the physical ID given in the *reg* property of that CPU node within the device tree.

- `size_dt_strings`

This field shall contain the length in bytes of the strings block section of the device tree blob.

- `size_dt_struct`

This field shall contain the length in bytes of the structure block section of the device tree blob.

8.3 Memory Reservation Block

8.3.1 Purpose

The *memory reservation block* provides the client program with a list of areas in physical memory which are *reserved*; that is, which shall not be used for general memory allocations. It is used to protect vital data structures from being overwritten by the client program. For example, on some systems with an IOMMU, the TCE (translation control entry) tables initialized by an ePAPR boot program would need to be protected in this manner. Likewise, any boot program code or data used during the client program's runtime would need to be reserved (e.g., RTAS on Open Firmware platforms). The ePAPR does not require the boot program to provide any such runtime components, but it does not prohibit implementations from doing so as an extension.

More specifically, a client program shall not access memory in a reserved region unless other information provided by the boot program explicitly indicates that it shall do so. The client program

1 may then access the indicated section of the reserved memory in the indicated manner. Methods by
 2 which the boot program can indicate to the client program specific uses for reserved memory may
 3 appear in this document, in optional extensions to it, or in platform-specific documentation.

4
 5 The reserved regions supplied by a boot program may, but are not required to, encompass the device
 6 tree blob itself. The client program shall ensure that it does not overwrite this data structure before it is
 7 used, whether or not it is in the reserved areas.

8
 9 Any memory that is declared in a memory node and is accessed by the boot program or caused to be
 10 accessed by the boot program after client entry must be reserved. Examples of this type of access
 11 include (e.g., speculative memory reads through a non-guarded virtual page).

Programming Note

This requirement is necessary because any memory that is not reserved may be accessed by the client program with arbitrary storage attributes.

13
 14 Any accesses to reserved memory by or caused by the boot program must be done as not Caching
 15 Inhibited and Memory Coherence Required (i.e., WIMG = 0bx01x), and additionally for Book III-S
 16 implementations as not Write Through Required (i.e., WIMG = 0b001x). Further, if the VLE storage
 17 attribute is supported, all accesses to reserved memory must be done as VLE=0.

Programming Note

This requirement is necessary because the client program is permitted to map memory with storage attributes specified as not Write Through Required, not Caching Inhibited, and Memory Coherence Required (i.e., WIMG = 0b001x), and VLE=0 where supported. The client program may use large virtual pages that contain reserved memory. However, the client program may not modify reserved memory, so the boot program may perform accesses to reserved memory as Write Through Required where conflicting values for this storage attribute are architecturally permissible.

8.3.2 Format

19
 20
 21
 22 The memory reservation block consists of a list of pairs of 64-bit big-endian integers, each pair being
 23 represented by the following C structure.

```
24
25     struct fdt_reserve_entry {
26         uint64_t address;
27         uint64_t size;
28     };
29
```

30 Each pair gives the physical address and size of a reserved memory region. These given regions shall
 31 not overlap each other. The list of reserved blocks shall be terminated with an entry where both

1 address and size are equal to 0. Note that the address and size values are always 64-bit. On 32-bit
 2 CPUs the upper 32-bits of the value are ignored.

3
 4 Each `uint64_t` in the memory reservation block, and thus the memory reservation block as a whole,
 5 shall be located at an 8-byte aligned offset from the beginning of the device tree blob (see 8.6)

6 **8.4 Structure Block**

7
 8 The structure block describes the structure and contents of the device tree itself. It is composed of a
 9 sequence of tokens with data, as described in 0. These are organized into a linear tree
 10 structure, as described in 0.

11
 12 Each token in the structure block, and thus the structure block itself, shall be located at a 4-byte
 13 aligned offset from the beginning of the device tree blob (see 8.6).

14 **8.4.1 Lexical structure**

15
 16 The structure block is composed of a sequence of pieces, each beginning with a *token*, that is, a big-
 17 endian 32-bit integer. Some tokens are followed by extra data, the format of which is determined
 18 by the token value. All tokens shall be aligned on a 32-bit boundary, which may require padding bytes
 19 (with a value of 0x0) to be inserted after the previous token's data.

20
 21 The five token types are as follows:

- 22
 23 ○ FDT_BEGIN_NODE (0x00000001)

24
 25 The FDT_BEGIN_NODE token marks the beginning of a node's representation. It shall be
 26 followed by the node's unit name as extra data. The name is stored as a null-terminated string,
 27 and shall include the unit address (see 2.2.1, *Node Names*), if any.

28
 29 The node name is followed by zeroed padding bytes, if necessary for alignment, and then the
 30 next token, which may be any token except FDT_END.

- 31
 32 ○ FDT_END_NODE (0x00000002)

33
 34 The FDT_END_NODE token marks the end of a node's representation. This token has no
 35 extra data; so it is followed immediately by the next token, which may be any token except
 36 FDT_PROP.

- 37
 38 ○ FDT_PROP (0x00000003)

39
 40 The FDT_PROP token marks the beginning of the representation of one property in the
 41 device tree. It shall be followed by extra data describing the property. This data consists first
 42 of the property's length and name represented as the following C structure:

```
43  

  44     struct {  

  45         uint32_t len;  

  46         uint32_t nameoff;
```

1 }

2

3

Both the fields in this structure are 32-bit big-endian integers.

4

- `len` gives the length of the property's value in bytes (which may be zero, indicating an empty property, see 2.2.4.2, *Property Values*).

5

- `nameoff` gives an offset into the strings block (see 8.5) at which the property's name is stored as a null-terminated string.

6

7

8

After this structure, the property's value is given as a byte string of length `len`. This value is followed by zeroed padding bytes (if necessary) to align to the next 32-bit boundary and then the next token, which may be any token except `FDT_END`.

10

11

12

- `FDT_NOP` (0x00000004)

14

The `FDT_NOP` token will be ignored by any program parsing the device tree. This token has no extra data; so it is followed immediately by the next token, which can be any valid token.

15

16

17

A property or node definition in the tree can be overwritten with `FDT_NOP` tokens to remove it from the tree without needing to move other sections of the tree's representation in the device tree blob.

18

19

20

21

- `FDT_END` (0x00000009)

22

23

The `FDT_END` token marks the end of the structure block. There shall be only one `FDT_END` token, and it shall be the last token in the structure block. It has no extra data; so the byte immediately after the `FDT_END` token has offset from the beginning of the structure block equal to the value of the `size_dt_struct` field in the device tree blob header.

24

25

26

27

28

29 8.4.2 Tree structure

30

The device tree structure is represented as a linear tree: the representation of each node begins with an `FDT_BEGIN_NODE` token and ends with an `FDT_END_NODE` token. The node's properties and subnodes (if any) are represented before the `FDT_END_NODE`, so that the `FDT_BEGIN_NODE` and `FDT_END_NODE` tokens for those subnodes are nested within those of the parent.

35

The structure block as a whole consists of the root node's representation (which contains the representations for all other nodes), followed by an `FDT_END` token to mark the end of the structure block as a whole.

36

37

38

39

More precisely, each node's representation consists of the following components:

41

- (optionally) any number of `FDT_NOP` tokens

42

- `FDT_BEGIN_NODE` token

43

- The node's name as a null-terminated string

44

- [zeroed padding bytes to align to a 4-byte boundary]

45

- For each property of the node:
-

- 1 ○ (optionally) any number of FDT_NOP tokens
- 2 ○ FDT_PROP token
- 3 ▪ property information as given in 8.4.1
- 4 ▪ [zeroed padding bytes to align to a 4-byte boundary]
- 5 • Representations of all child nodes in this format
- 6 • (optionally) any number of FDT_NOP tokens
- 7 • FDT_END_NODE token

8
9 Note that this process requires that all property definitions for a particular node precede any subnode
10 definitions for that node. Although the structure would not be ambiguous if properties and subnodes
11 were intermingled, the code needed to process a flat tree is simplified by this requirement.

12 **8.5 Strings Block**

13
14 The strings block contains strings representing all the property names used in the tree. These null-
15 terminated strings are simply concatenated together in this section, and referred to from the structure
16 block by an offset into the strings block.

17
18 The strings block has no alignment constraints and may appear at any offset from the beginning of the
19 device tree blob.

20
21

1 **8.6 Alignment**

2
3 For the data in the memory reservation and structure blocks to be used without unaligned memory
4 accesses, they shall lie at suitably aligned memory addresses. Specifically, the memory reservation
5 block shall be aligned to an 8-byte boundary and the structure block to a 4-byte boundary.

6
7 Furthermore, the device tree blob as a whole can be relocated without destroying the alignment of the
8 subblocks.

9
10 As described in the previous sections, the structure and strings blocks shall have aligned offsets from
11 the beginning of the device tree blob. To ensure the in-memory alignment of the blocks, it is sufficient
12 to ensure that the device tree as a whole is loaded at an address aligned to the largest alignment of any
13 of the subblocks, that is, to an 8-byte boundary. As described in 5.2 (*Device Tree*) an ePAPR-
14 compliant boot program shall load the device tree blob at such an aligned address before passing it to
15 the client program. If an ePAPR client program relocates the device tree blob in memory, it should
16 only do so to another 8-byte aligned address.

17
18

1 Appendix A Device Tree Source Format (version 1)

2
3 The Device Tree Source (DTS) format is a textual representation of a device tree in a form that can be
4 processed by dtc into a binary device tree in the form expected by the kernel. The following
5 description is not a formal syntax definition of DTS, but describes the basic constructs used to
6 represent device trees.
7

8 Node and property definitions

9
10 Device tree nodes are defined with a node name and unit address with braces marking the start and
11 end of the node definition. They may be preceded by a label.
12

```
13     [label:] node-name[@unit-address] {
14         [properties definitions]
15         [child nodes]
16     }
```

17
18 Nodes may contain property definitions and/or child node definitions. If both are present, properties
19 shall come before child nodes.
20

21 Property definitions are name value pairs in the form:

```
22     [label:] property-name = value;
```

23
24 except for properties with empty (zero length) value which have the form:

```
25     [label:] property-name;
```

26
27 Property values may be defined as an array of 32-bit integer cells, as null-terminated strings, as
28 bytestrings or a combination of these.
29

- 30 • Arrays of cells are represented by angle brackets surrounding a space separated list of C-style
31 integers. Example:

```
32     interrupts = <17 0xc>;
```

- 34 • A 64-bit value is represented with two 32-bit cells. Example:

```
35     clock-frequency = <0x00000001 0x00000000>;
```

- 37 • A null-terminated string value is represented using double quotes (the property value is
38 considered to include the terminating NULL character). Example:

```
39     compatible = "simple-bus";
```

- 41 • A bytestring is enclosed in square brackets [] with each byte represented by two hexadecimal
42 digits. Spaces between each byte are optional. Example:

```
43     local-mac-address = [00 00 12 34 56 78];
```

44 or equivalently:

```
45     local-mac-address = [000012345678];
```

-
- 1 • Values may have several comma-separated components, which are concatenated together.
2 Example:
3 `compatible = "ns16550", "ns8250";`
4 `example = <0xf00f0000 19>, "a strange property format";`
5
 - 6 • In a cell array a reference to another node will be expanded to that node's phandle.
7 References may be `&` followed by a node's label. Example:
8 `interrupt-parent = < &mpic >;`
9
 - 10 or they may be `&` followed by a node's full path in braces. Example:
11 `interrupt-parent = < &{/soc/interrupt-controller@40000} >;`
12
 - 13 • Outside a cell array, a reference to another node will be expanded to that node's full path.
14 Example:
15 `ethernet0 = &EMAC0;`
16
 - 17 • Labels may also appear before or after any component of a property value, or between cells of
18 a cell array, or between bytes of a bytestring. Examples:
19 `reg = reglabel: <0 sizelabel: 0x1000000>;`
20 `prop = [ab cd ef byte4: 00 ff fe];`
21 `str = start: "string value" end: ;`
22

23 File layout

24
25 Version 1 DTS files have the overall layout:

```
26 /dts-v1/;
27
28 [memory reservations]
29
30 / {
31     [property definitions]
32     [child nodes]
33 };
34
35
```

- 36 • The `/dts-v1/;` shall be present to identify the file as a version 1 DTS (dts files without this tag
37 will be treated by dtc as being in the obsolete version 0, which uses a different format for
38 integers in addition to other small but incompatible changes).
39
 - 40 • Memory reservations define an entry for the device tree blob's memory reservation table.
41 They have the form:
42 `e.g., /memreserve/ <address> <length>;`
43
44 Where `<address>` and `<length>` are 64-bit C-style integers.
45
 - 46 • The `/ { ... };` section defines the root node of the device tree.
47
 - 48 • C style (`/* ... */`) and C++ style (`// ...`) comments are supported.
49
-

1 Appendix B1 Ebony Device Tree

2
3 This appendix shows a complete device tree for the IBM 440-based Ebony system.

```
4  
5 /*  
6  * Device Tree Source for IBM Ebony  
7  *  
8  * Copyright (c) 2006, 2007 IBM Corp.  
9  * Josh Boyer <jwboyer@linux.vnet.ibm.com>, David Gibson <dwg@aul.ibm.com>  
10 *  
11 *  
12 *  
13 * This file is licensed under the terms of the GNU General Public  
14 * License version 2. This program is licensed "as is" without  
15 * any warranty of any kind, whether express or implied.  
16 */  
17 /dts-v1/;  
18 / {  
19     #address-cells = <0x2>;  
20     #size-cells = <0x1>;  
21     model = "ibm,ebony";  
22     compatible = "ibm,ebony";  
23     dcr-parent = <&/cpus/cpu@0>;  
24  
25     aliases {  
26         ethernet0 = &EMAC0;  
27         ethernet1 = &EMAC1;  
28         serial0 = &UART0;  
29         serial1 = &UART1;  
30     };  
31  
32     cpus {  
33         #address-cells = <0x1>;  
34         #size-cells = <0x0>;  
35  
36         cpu@0 {  
37             device_type = "cpu";  
38             model = "PowerPC,440GP";  
39             reg = <0x0>;  
40             clock-frequency = <0x179a7b00>;  
41             timebase-frequency = <0x179a7b00>;  
42             i-cache-line-size = <0x20>;  
43             d-cache-line-size = <0x20>;  
44             i-cache-size = <0x8000>;  
45             d-cache-size = <0x8000>;  
46             dcr-controller;  
47             dcr-access-method = "native";  
48         };  
49     };  
50  
51     memory {  
52         device_type = "memory";  
53         reg = <0x0 0x0 0x80000000>;  
54     };  
55
```

```
1  UIC0: interrupt-controller0 {
2      compatible = "ibm,uic-440gp", "ibm,uic";
3      interrupt-controller;
4      cell-index = <0x0>;
5      dcr-reg = <0xc0 0x9>;
6      #address-cells = <0x0>;
7      #size-cells = <0x0>;
8      #interrupt-cells = <0x2>;
9  };
10
11 UIC1: interrupt-controller1 {
12     compatible = "ibm,uic-440gp", "ibm,uic";
13     interrupt-controller;
14     cell-index = <0x1>;
15     dcr-reg = <0xd0 0x9>;
16     #address-cells = <0x0>;
17     #size-cells = <0x0>;
18     #interrupt-cells = <0x2>;
19     interrupt-parent = <&UIC1>;
20     interrupts = <0x1e 0x4 0x1f 0x4>;
21 };
22
23 cpc {
24     compatible = "ibm,cpc-440gp";
25     dcr-reg = <0xb0 0x3 0xe0 0x10>;
26 };
27
28 plb {
29     compatible = "ibm,plb-440gp", "ibm,plb4";
30     #address-cells = <0x2>;
31     #size-cells = <0x1>;
32     ranges;
33     clock-frequency = <0x7de2900>;
34
35     sram {
36         compatible = "ibm,sram-440gp";
37         dcr-reg = <0x20 0x8 0xa 0x1>;
38     };
39
40     dma {
41         compatible = "ibm,dma-440gp";
42         dcr-reg = <0x100 0x27>;
43     };
44
45     MAL0: mcmal {
46         compatible = "ibm,mcmal-440gp", "ibm,mcmal";
47         dcr-reg = <0x180 0x62>;
48         num-rx-chans = <0x4>;
49         num-tx-chans = <0x4>;
50         interrupt-parent = <&MAL0>;
51         interrupts = <0x0 0x1 0x2 0x3 0x4>;
52         #interrupt-cells = <0x1>;
53         #address-cells = <0x0>;
54         #size-cells = <0x0>;
55         interrupt-map = <
56             0 &UIC0 a 4
57             1 &UCIO b 4
```

```
1         2 &UCI1 0 4
2         3 &UCI1 1 4
3         4 &UIC1 2 4>;
4     interrupt-map-mask = <0xffffffff>;
5 };
6
7     POB0: opb {
8         compatible = "ibm,opb-440gp", "ibm,opb";
9         #address-cells = <0x1>;
10        #size-cells = <0x1>;
11        ranges = <0x00000000 0x1 0x00000000 0x80000000
12              0x80000000 0x1 0x80000000 0x80000000>;
13        dcr-reg = <0x90 0xb>;
14        interrupt-parent = <&UIC1>;
15        interrupts = <0x7 0x4>;
16        clock-frequency = <0x3ef1480>;
17
18        ebc {
19            compatible = "ibm,ebc-440gp", "ibm,ebc";
20            dcr-reg = <0x12 0x2>;
21            #address-cells = <0x2>;
22            #size-cells = <0x1>;
23            clock-frequency = <0x3ef1480>;
24            ranges = <
25                0x0 0x0 0xffff0000 0x100000
26                0x1 0x0 0x48000000 0x100000
27                0x2 0x0 0xff800000 0x400000
28                0x3 0x0 0x48200000 0x100000
29                0x7 0x0 0x48300000 0x100000>;
30            interrupts = <0x5 0x4>;
31            interrupt-parent = <&UIC1>;
32
33            fpga@7,0 {
34                compatible = "Ebony-FPGA";
35                reg = <0x7 0x0 0x10>;
36                virtual-reg = <0xe8300000>;
37            };
38
39            ir@3,0 {
40                reg = <0x3 0x0 0x10>;
41            };
42
43            large-flash@2,0 {
44                compatible = "jedec-flash";
45                bank-width = <0x1>;
46                reg = <0x2 0x0 0x400000>;
47                #address-cells = <0x1>;
48                #size-cells = <0x1>;
49
50            partition@380000 {
51                reg = <0x380000 0x80000>;
52                label = "firmware";
53            };
54
55            partition@0 {
56                reg = <0x0 0x380000>;
57                label = "fs";
58            };

```

1
2

};

```
1
2     nvram@1,0 {
3         compatible = "ds1743-nvram";
4         reg = <0x1 0x0 0x2000>;
5         #bytes = <0x2000>;
6     };
7
8     small-flash@0,80000 {
9         compatible = "jedec-flash";
10        bank-width = <0x1>;
11        reg = <0x0 0x80000 0x80000>;
12        #address-cells = <0x1>;
13        #size-cells = <0x1>;
14
15        partition@0 {
16            read-only;
17            reg = <0x0 0x80000>;
18            label = "OpenBIOS";
19        };
20    };
21 };
22
23 UART0: serial@40000200 {
24     device_type = "serial";
25     compatible = "ns16550";
26     reg = <0x40000200 0x8>;
27     virtual-reg = <0xe0000200>;
28     clock-frequency = <0xa8c000>;
29     current-speed = <0x2580>;
30     interrupts = <0x0 0x4>;
31     interrupt-parent = <&UIC0>;
32 };
33
34 UART1: serial@40000300 {
35     device_type = "serial";
36     compatible = "ns16550";
37     reg = <0x40000300 0x8>;
38     virtual-reg = <0xe0000300>;
39     clock-frequency = <0xa8c000>;
40     current-speed = <0x2580>;
41     interrupts = <0x1 0x4>;
42     interrupt-parent = <&UIC0>;
43 };
44
45 i2c@40000400 {
46     compatible = "ibm,iic-440gp", "ibm,iic";
47     reg = <0x40000400 0x14>;
48     interrupts = <0x2 0x4>;
49     interrupt-parent = <&UIC0>;
50 };
51
52 i2c@40000500 {
53     compatible = "ibm,iic-440gp", "ibm,iic";
54     reg = <0x40000500 0x14>;
55     interrupts = <0x3 0x4>;
56     interrupt-parent = <&UIC0>;
57 };
58
```

```
1
2     gpio@40000700 {
3         compatible = "ibm,gpio-440gp";
4         reg = <0x40000700 0x20>;
5     };
6
7     ZMII0: emac-zmii@40000780 {
8         compatible = "ibm,zmii-440gp", "ibm,zmii";
9         reg = <0x40000780 0xc>;
10    };
11
12    EMAC0: ethernet@40000800 {
13        linux,network-index = <0x0>;
14        device_type = "network";
15        compatible = "ibm,emac-440gp", "ibm,emac";
16        interrupts = <0x1c 0x4 0x1d 0x4>;
17        interrupt-parent = <&UIC1>;
18        reg = <0x40000800 0x70>;
19        local-mac-address = [00 04 ac e3 1b 0b];
20        mal-device = <&MAL0>;
21        mal-tx-channel = <0x0 0x1>;
22        mal-rx-channel = <0x0>;
23        cell-index = <0x0>;
24        max-frame-size = <0x5dc>;
25        rx-fifo-size = <0x1000>;
26        tx-fifo-size = <0x800>;
27        phy-mode = "rmii";
28        phy-map = <0x1>;
29        zmii-device = <&ZMII0>;
30        zmii-channel = <0x0>;
31    };
32
33    EMAC1: ethernet@40000900 {
34        linux,network-index = <0x1>;
35        device_type = "network";
36        compatible = "ibm,emac-440gp", "ibm,emac";
37        interrupts = <0x1e 0x4 0x1f 0x4>;
38        interrupt-parent = <&UIC1>;
39        reg = <0x40000900 0x70>;
40        local-mac-address = [00 04 ac e3 1b 0c];
41        mal-device = <&MAL0>;
42        mal-tx-channel = <0x2 0x3>;
43        mal-rx-channel = <0x1>;
44        cell-index = <0x1>;
45        max-frame-size = <0x5dc>;
46        rx-fifo-size = <0x1000>;
47        tx-fifo-size = <0x800>;
48        phy-mode = "rmii";
49        phy-map = <0x1>;
50        zmii-device = <&ZMII0>;
51        zmii-channel = <0x1>;
52    };
53
54    gpt@40000a00 {
55        reg = <0x40000a00 0xd4>;
56        interrupts = <0x12 0x4 0x13 0x4 0x14 0x4 0x15 0x4 0x16 0x4>;
57        interrupt-parent = <&UIC0>;
```

```
1     };
2   };
3
4   PCI_X0: pci@20ec00000 {
5     device_type = "pci";
6     #interrupt-cells = <0x1>;
7     #size-cells = <0x2>;
8     #address-cells = <0x3>;
9     compatible = "ibm,plb440gp-pcix", "ibm,plb-pcix";
10    primary;
11    reg = <0x2 0xec00000 0x8
12         0x0 0x0 0x0
13         0x2 0xed00000 0x4
14         0x2 0xec80000 0xf0
15         0x2 0xec80100 0xfc>;
16
17    ranges = <0x2000000 0x0 0x80000000 0x3 0x80000000 0x0 0x80000000
18             0x1000000 0x0 0x0 0x2 0x80000000 0x0 0x10000>;
19
20    dma-ranges = <0x42000000 0x0 0x0 0x0 0x0 0x0 0x80000000>;
21
22    interrupt-map-mask = <0xf800 0x0 0x0 0x0>;
23    interrupt-map = <
24        0x800 0x0 0x0 0x0 &UIC0 0x17 0x8
25        0x1000 0x0 0x0 0x0 &UIC0 0x18 0x8
26        0x1800 0x0 0x0 0x0 &UIC0 0x19 0x8
27        0x2000 0x0 0x0 0x0 &UIC0 0x1a 0x8>;
28    };
29  };
30 };
31
32
33
```

1 Appendix B2 – MPC8572DS Device Tree

2 This appendix shows a device tree for the Freescale MPC8572DS system. **Note:** to
3 simplify the example, some portions of the device tree have been removed.

```
4
5 /*
6  * MPC8572 DS Device Tree Source
7  *
8  * Copyright 2007-2009 Freescale Semiconductor Inc.
9  *
10 * This program is free software; you can redistribute it and/or modify it
11 * under the terms of the GNU General Public License as published by the
12 * Free Software Foundation; either version 2 of the License, or (at your
13 * option) any later version.
14 */
15
16 /dts-v1/;
17 / {
18     model = "fsl,MPC8572DS";
19     compatible = "fsl,MPC8572DS";
20     #address-cells = <2>;
21     #size-cells = <2>;
22
23     aliases {
24         ethernet0 = &enet0;
25         ethernet1 = &enet1;
26         ethernet2 = &enet2;
27         ethernet3 = &enet3;
28         serial0 = &serial0;
29         serial1 = &serial1;
30         pci0 = &pci0;
31         pci1 = &pci1;
32         pci2 = &pci2;
33     };
34
35     cpus {
36         #address-cells = <1>;
37         #size-cells = <0>;
38
39         cpu@0 {
40             device_type = "cpu";
41             reg = <0x0>;
42             d-cache-line-size = <32>; // 32 bytes
43             i-cache-line-size = <32>; // 32 bytes
44             d-cache-size = <0x8000>; // L1, 32K
45             i-cache-size = <0x8000>; // L1, 32K
46             timebase-frequency = <0>;
47             bus-frequency = <0>;
48             clock-frequency = <0>;
49             next-level-cache = <&L2>;
50         };
51
52         cpu@1 {
53             device_type = "cpu";
54             reg = <0x1>;
```



```
1         d-cache-line-size = <32>;      // 32 bytes
2         i-cache-line-size = <32>;      // 32 bytes
3         d-cache-size = <0x8000>;       // L1, 32K
4         i-cache-size = <0x8000>;       // L1, 32K
5         timebase-frequency = <0>;
6         bus-frequency = <0>;
7         clock-frequency = <0>;
8         next-level-cache = <&L2>;
9     };
10 };
11
12 memory {
13     device_type = "memory";
14 };
15
16 soc {
17     #address-cells = <1>;
18     #size-cells = <1>;
19     compatible = "simple-bus";
20     ranges = <0x0 0 0xffe00000 0x100000>;
21     bus-frequency = <0>;              // Filled out by uboot.
22     interrupt-parent = <&mpic>;
23
24     ecm-law@0 {
25         compatible = "fsl,ecm-law";
26         reg = <0x0 0x1000>;
27         fsl,num-laws = <12>;
28     };
29
30     ecm@1000 {
31         compatible = "fsl,mpc8572-ecm", "fsl,ecm";
32         reg = <0x1000 0x1000>;
33         interrupts = <17 2>;
34     };
35
36     memory-controller@2000 {
37         compatible = "fsl,mpc8572-memory-controller";
38         reg = <0x2000 0x1000>;
39         interrupts = <18 2>;
40     };
41
42     memory-controller@6000 {
43         compatible = "fsl,mpc8572-memory-controller";
44         reg = <0x6000 0x1000>;
45         interrupts = <18 2>;
46     };
47
48     L2: l2-cache-controller@20000 {
49         compatible = "fsl,mpc8572-l2-cache-controller";
50         reg = <0x20000 0x1000>;
51         cache-line-size = <32>;        // 32 bytes
52         cache-size = <0x100000>;      // L2, 1M
53         interrupts = <16 2>;
54     };
55
56     i2c@3000 {
57         #address-cells = <1>;
58         #size-cells = <0>;
```

```
1         cell-index = <0>;
2         compatible = "fsl-i2c";
3         reg = <0x3000 0x100>;
4         interrupts = <43 2>;
5         dfsrr;
6     };
7
8     enet0: ethernet@24000 {
9         #address-cells = <1>;
10        #size-cells = <1>;
11        cell-index = <0>;
12        model = "eTSEC";
13        compatible = "gianfar";
14        reg = <0x24000 0x1000>;
15        ranges = <0x0 0x24000 0x1000>;
16        local-mac-address = [ 00 00 00 00 00 00 ];
17        interrupts = <29 2 30 2 34 2>;
18        tbi-handle = <&tbi0>;
19        phy-handle = <&phy0>;
20        phy-connection-type = "rgmii-id";
21
22        mdio@520 {
23            #address-cells = <1>;
24            #size-cells = <0>;
25            compatible = "fsl,gianfar-mdio";
26            reg = <0x520 0x20>;
27
28            phy0: ethernet-phy@0 {
29                interrupts = <10 1>;
30                reg = <0x0>;
31            };
32
33            tbi0: tbi-phy@11 {
34                reg = <0x11>;
35                device_type = "tbi-phy";
36            };
37        };
38    };
39
40    serial0: serial@4500 {
41        cell-index = <0>;
42        compatible = "ns16550";
43        reg = <0x4500 0x100>;
44        clock-frequency = <0>;
45        interrupts = <42 2>;
46    };
47
48    serial1: serial@4600 {
49        cell-index = <1>;
50        compatible = "ns16550";
51        reg = <0x4600 0x100>;
52        clock-frequency = <0>;
53        interrupts = <42 2>;
54    };
55
56    global-utilities@e0000 { //global utilities block
57        compatible = "fsl,mpc8572-guts";
```

```
1         reg = <0xe0000 0x1000>;
2         fsl,has-rstcr;
3     };
4
5     msi@41600 {
6         compatible = "fsl,mpc8572-msi", "fsl,mpic-msi";
7         reg = <0x41600 0x80>;
8         msi-available-ranges = <0 0x100>;
9         interrupts = <
10             0xe0 0
11             0xe1 0
12             0xe2 0
13             0xe3 0
14             0xe4 0
15             0xe5 0
16             0xe6 0
17             0xe7 0>;
18     };
19
20     crypto@30000 {
21         compatible = "fsl,sec3.0", "fsl,sec2.4", "fsl,sec2.2",
22             "fsl,sec2.1", "fsl,sec2.0";
23         reg = <0x30000 0x10000>;
24         interrupts = <45 2 58 2>;
25         fsl,num-channels = <4>;
26         fsl,channel-fifo-len = <24>;
27         fsl,exec-units-mask = <0x9fe>;
28         fsl,descriptor-types-mask = <0x3ab0ebf>;
29     };
30
31     mpic: pic@40000 {
32         interrupt-controller;
33         #address-cells = <0>;
34         #interrupt-cells = <2>;
35         reg = <0x40000 0x40000>;
36         compatible = "chrp,open-pic";
37     };
38 };
39
40     pcil: pcie@ffe09000 {
41         compatible = "fsl,mpc8548-pcie";
42         #interrupt-cells = <1>;
43         #size-cells = <2>;
44         #address-cells = <3>;
45         reg = <0 0xffe09000 0 0x1000>;
46         bus-range = <0 255>;
47         ranges = <0x2000000 0x0 0xa0000000 0 0xa0000000 0x0 0x20000000
48             0x1000000 0x0 0x00000000 0 0xffc10000 0x0 0x00010000>;
49         clock-frequency = <33333333>;
50         interrupt-parent = <&mpic>;
51         interrupts = <25 2>;
52         interrupt-map-mask = <0xf800 0x0 0x0 0x7>;
53         interrupt-map = <
54             /* IDSEL 0x0 */
55             0000 0x0 0x0 0x1 &mpic 0x4 0x1
56             0000 0x0 0x0 0x2 &mpic 0x5 0x1
57             0000 0x0 0x0 0x3 &mpic 0x6 0x1
58             0000 0x0 0x0 0x4 &mpic 0x7 0x1
```

```
1         >;
2     pcie@0 {
3         reg = <0x0 0x0 0x0 0x0 0x0>;
4         #size-cells = <2>;
5         #address-cells = <3>;
6         ranges = <0x2000000 0x0 0xa0000000
7                 0x2000000 0x0 0xa0000000
8                 0x0 0x20000000
9
10                0x1000000 0x0 0x0
11                0x1000000 0x0 0x0
12                0x0 0x10000>;
13     };
14 };
15
16 };
```